



**Capital Area Transportation Authority**  
**4615 Tranter Street**  
**Lansing, MI 48910**

**REQUEST FOR QUOTE**  
**BUS STOP IMPROVEMENTS**  
**RFQ 2025-572**

<b>1. SOLICITATION No:</b> RFQ 2025-572	<b>2. ISSUE DATE:</b> May 7, 2025
<b>3. FOR INFORMATION CONTACT</b> <b>NAME:</b> Andrea Fisher <b>E-MAIL:</b> <a href="mailto:afisher@cata.org">afisher@cata.org</a>	<b>PHONE:</b> 517.394.1100

**4. DESCRIPTION:**

The Capital Area Transportation Authority ("CATA") in Lansing, Michigan, is requesting pricing for Bus Stop Improvements in accordance with the Scope of Work as described in Exhibit A.

ALL QUESTIONS MUST BE SUBMITTED VIA EMAIL TO: Andrea Fisher ([afisher@cata.org](mailto:afisher@cata.org)) by May 14<sup>th</sup>, 2025. CATA will provide responses to vendor questions May 21<sup>st</sup>, 2025.

**QUOTES MUST BE SUBMITTED VIA EMAIL TO:**  
 Capital Area Transportation Authority  
 Attn: Andrea Fisher, Procurement Specialist  
[afisher@cata.org](mailto:afisher@cata.org)

Quotes for "BUS STOP IMPROVEMENTS" submitted to Capital Area Transportation Authority, Lansing, Michigan will be received at [afisher@cata.org](mailto:afisher@cata.org) until June 4, 2025, 11:00 A.M. Eastern Time. Emails received at 11:01 AM Eastern Time or later, will be considered NON-RESPONSIVE.

CATA email accepts up to 50MB. It is the vendor's responsibility to ensure each email sent to CATA does not exceed 50MB.

**5. QUOTES DUE BY: June 4, 2025, at 11:00 A.M. EASTERN TIME**

**6. FIRM OFFER PERIOD:** Offers shall remain firm for a period of **120** calendar days from the date specified above or as amended.

**7.** If this Quote is accepted within the period specified above, Bidder agrees to fully provide the goods and/or services covered by this solicitation at the prices and timelines specified in the solicitation.

**8. The following Exhibits, if indicated, are included in this solicitation:**

<input checked="" type="checkbox"/>	EXHIBIT A – Scope of Work	<input checked="" type="checkbox"/>	EXHIBIT B – Pricing Schedule	<input checked="" type="checkbox"/>	EXHIBIT C – Submittal Checklist
<input checked="" type="checkbox"/>	EXHIBIT D – Iran Economic Sanctions Act Certificate	<input checked="" type="checkbox"/>	EXHIBIT E – Bidder's Offer & Guarantees	<input checked="" type="checkbox"/>	EXHIBIT F – Debarment & Suspension - Primary
<input checked="" type="checkbox"/>	EXHIBIT G – Debarment & Suspension – Lower-Tier	<input checked="" type="checkbox"/>	EXHIBIT H – Bidders List Data Form	<input checked="" type="checkbox"/>	EXHIBIT I – CATA Terms & Conditions
<input checked="" type="checkbox"/>	EXHIBIT J – Wage Determination				

## EXHIBIT A SCOPE OF WORK

**BASIS OF AWARD:** The award of this order is based on the lowest responsive and responsible bidder(s) as determined by the Capital Area Transportation Authority (CATA).

**Please Note:** This bid package and any amendments are available at [www.cata.org](http://www.cata.org). Please continue checking the website for any updates or amendments.

### 1. Objectives

The specific objectives for this Project are to secure a contract for bus stop improvements.

### 2. General Provisions

- a) The contractor shall furnish all labor, tools and materials necessary for the bus stop improvements as listed in this Scope of Work.
- b) The Contractor shall provide CATA's Project Manager with a work schedule.
- c) The Contractor assumes full responsibility for protection and safekeeping of materials and equipment on-site.
- d) All work must conform to all state and local construction regulations. The contractor will be responsible for obtaining and paying for all required permits. The contractor will be responsible for coordinating and scheduling all work with CATA Staff, Miss Dig and local municipalities and jurisdictions.
- e) The Contractor will notify CATA's Project Manager of any findings during the project and submit a cost proposal for any additional work required. No additional work shall commence until approved by CATA's Project Manager.
- f) The Contractor will be responsible for clean up at the end of each work day.
- g) BID BOND INFORMATION – a 5% Bid Bond is required to be submitted with all vendor quotes. If awarded the contract, a 100% Payment and Performance Bond are required and must be submitted to CATA within five (5) business days of award.
- h) All required payroll records and required documents to comply with the requirements of Davis Bacon Act. Proper documentation will be required in order to receive payment.

### 3. Service Period

CATA intends to award a firm fixed price contract. The services of the Contractor will be based on the Scope of Work.

### 4. Scope of Work

The purpose of this Request for Quote (RFQ) is to procure a qualified, responsive and responsible Contractor to remove, replace and or install ADA accessible concrete pad(s). The Contractor will responsible for removing existing concrete pad(s), pouring concrete pad(s), grading and landscaping at existing stop locations.

Contractor, at the direction of CATA's Facilities Manager, shall provide Bus Stop Improvements accordance with the specifications, tasks, and scope of work set forth in Exhibit A. It is the sole responsibility of Contractor to read the specifications and understand them. Contractor shall construct concrete pads according to attached Bus Stop Information (**see Attachment A**). Site plans are not to scale and are only meant to be used as a visual guide for the construction of the concrete pads. It is the contractor's responsibility to verify all dimensions.

<u>Bus Stop ID #'s</u>	<u>Bus Stop Site Locations:</u>
1990	NBD Cedar St, E. Elm St. Lansing, MI 48912
5740	EBD N. Grand Ave, E. Saginaw St. Lansing, MI 48933
3789	WBD W. North St., N Washington Ave Lansing, MI 48906

Site plans are not to scale and are only meant to be used as a visual guide for the construction of the concrete pads. It is the contractor's responsibility to verify all dimensions. (See Attachment A)

#### Site Specifications:

- All concrete pads will be a minimum of 6" thick continuously with 6 x 6 standard steel mesh.
- All concrete shall have a compressive strength of 4000 psi.
- All expansion joints at existing pavement require speed dowels, per attached drawing (**see Attachment B**).

- Concrete control joints will be hand-tooled to at least ¼ of concrete thickness, or a minimum of 1 1/2" or saw cut.
  - Finish pads to a non-slip surface with a broom finish, free from defects, vandalism, graffiti and blemishes.
  - Concrete pads shall have 1/8" per foot of slope to provide for water run-off.
  - Concrete pads will be set on a level and stable 4" base of 21 AA gravel that has been properly compacted to 95% density.
  - It shall be the contractor's responsibility to repair or reroute all lawn irrigation lines in the affected area.
  - It shall be the contractor's responsibility to backfill with screened topsoil and reseed grass with straw or straw blanket if slope requires to all areas affected by site construction.
  - All work must meet the requirements of the American Disabilities Act (ADA). The contractor is responsible to visit each site location to determine the work required to meet the ADA. ADA requires no more than an 8.3% grade (1" per foot) for 20' with a minimum 5' x 5' resting area with no more than a 2% grade (¼" per foot). Bus boarding area pads require a minimum 5' x 5' clear boarding area with no more than 2% grade. Bus stop bench and shelter pads must be poured with no more than 2% grade.
  - Contractor is responsible for replacing any and all concrete that is not in ADA compliance in regards to the specific site.
  - Contractor shall contact Project Manager after forms are set before pouring.
  - Contractor is responsible for protecting any existing concrete and replacing any damaged concrete due to construction.
  - Contractor is responsible for de-watering.
  - Contractor to clean up all job debris, including removal and disposal of all debris.
  - Contractor is responsible for all traffic warning and road signs required to perform this work. This cost and all other costs must be included in their bid.
  - Contractor assumes full responsibility for protection and safekeeping of materials and equipment on-site. Barricades must be placed around each excavation and concrete pour. The construction site must be made safe and hazard free at all times until the work is completed. The contractor shall be responsible for and the repair of any vandalism that may occur to the shelter pads while the cement is still wet.
  - Refer to Attachment B, joint specifications.
  - If existing appurtenances or utilities are found to interfere with the permanent facilities being constructed, the contractor shall immediately notify CATA's Project Manager.
  - The Contractor will notify the CATA Project Manager of any findings during the project and submit a cost proposal for any additional work required. No additional work shall commence until approved by the Project Manager.
  - If necessary Contractor is responsible for all traffic warning and road signs required to perform this work. This cost and all other costs must be included in their bid.
  - Concrete shall be cured in accordance with ACI 301 procedures and as described herein. Water loss from new concrete will be limited to a rate of 1 lb./sq. ft. per 72 hours. Protect freshly placed concrete from premature drying and excessive cold or hot temperatures. Comply with ACI 306.1 for cold-weather protection and ACI 301 for hot-weather protection during curing
  - The sodium silicate base curing compounds that follow are compatible with the CATA's preferred sealer, most resilient floor covering adhesives, and many paint finishes.
  - 1. "Gardseal"; Lambert Corporation 2. "Sonosil"; Sonnebore Building Products Div. (BASF Building Systems)
5. CATA requires all of the work to be completed on or before Friday, July 25, 2025 @ 5:00 P.M. Eastern Time. NOTE: The allotted time is sufficient to complete the work. Therefore, no additional time will be allotted.
6. This solicitation does not obligate CATA to contract for the services specified herein. CATA reserves the right to remove and otherwise modify the site locations.
7. Vendor to provide CATA with a project schedule.
8. The contractor must submit certified payroll with each invoice. All work done under the Contract resulting from this RFQ must comply with Davis-Bacon Requirements (if applicable).
9. Payment shall be made as follows; 75% upon completion of the bus stop improvements; remaining 25% will be paid upon receipt of certified payroll records (for prevailing wage), providing the records meet CATA's requirements and any/all punch list items are completed.
10. Permits and Approvals (if applicable) – All work must conform to all state and local construction regulations.
- a) The Contractor will be responsible for obtaining all necessary permits.
  - b) The contractor will be responsible for coordinating and scheduling all work with CATA Staff, Miss Dig and local municipalities and jurisdictions.
  - c) The Contractor will be responsible for scheduling inspection(s) and must obtain approval for completed work before submitting invoice. Copies of approval for completed work must accompany relevant invoices.
  - d) The Contractor will be responsible for payment of all permits and inspections.

11. The Contractor shall provide a minimum of a thirty (30) day warranty against defects of materials, services, and workmanship.
12. Prices quoted will include all fees. Prices should be based on CATA's status as a tax exempt, municipal government agency.
13. Each Contractor should make every effort to include Disadvantaged Business Enterprises in this project. CATA has a Disadvantaged Business Enterprise goal of 1.28%.
14. All materials and documents submitted by the proposer in response to this RFQ shall become the property of the CATA and shall not be returned. As CATA is a public entity, this information may be subject to disclosure to third parties. CATA cannot and will not treat any materials submitted as confidential, even if it is marked as such. Proposers will not be provided with notice prior to disclosure to third parties.

### ATTACHMENT A

647

## BUS STOP INFORMATION

Date 4-8-25

Route 5 Inbound  Outbound  Trapeze ID 1990

GPS Latitude 42.722133 Longitude -81.545287 Capital Asset # \_\_\_\_\_

Nearest Crossroads Cedar st. E. Elm st.

Landmark-Corner / direction from Intersection North

#### Amenities at location

- New Bus Stop / Shelter  Service Mount Base \_\_\_\_\_ In-Ground Base
- Bench
- Ash Try
- Trash Receptacle / Pole Mount \_\_\_\_\_ 15 Gal \_\_\_\_\_ 30 Gal \_\_\_\_\_ 50 Gal \_\_\_\_\_
- Install Information Sign / Type \_\_\_\_\_ Quantity \_\_\_\_\_ Size \_\_\_\_\_
- Other / \_\_\_\_\_

Digital Photograph Taken Yes  No  Photo # 87

Shelter/bench on private property or in right a way R.O.W

Shelter Make, Model and Size \_\_\_\_\_

Cement Size 10' x 25' x 5' x Square Footage 459 Sq'

Special Remarks Demo 177 Sq' of existing walk, replace with 459 Sq' of new concrete

#### Drawing Layout

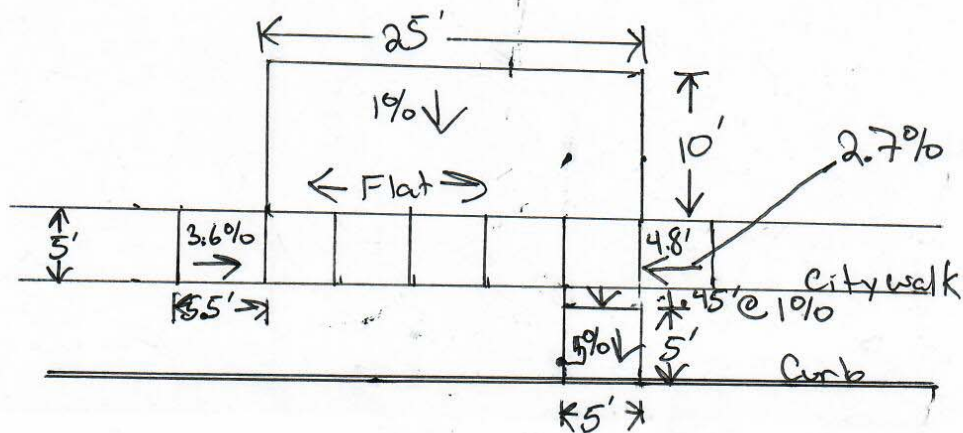





### BUS STOP INFORMATION

Date 4-8-25

Route 13 Inbound \_\_\_\_\_ Outbound X Trapeze ID 5740

GPS Latitude 42.740751 Longitude -84.548399 Capital Asset # \_\_\_\_\_

Nearest Crossroads N. Grand ave / E. Saginaw st.

Landmark-Corner / direction from Intersection East

#### Amenities at location

- New Bus Stop / Shelter  Service Mount Base  In-Ground Base \_\_\_\_\_
- Bench
- Ash Try
- Trash Receptacle / Pole Mount \_\_\_\_\_ 15 Gal \_\_\_\_\_ 30 Gal \_\_\_\_\_ 50 Gal \_\_\_\_\_
- Install Information Sign / Type \_\_\_\_\_ Quantity \_\_\_\_\_ Size \_\_\_\_\_
- Other / \_\_\_\_\_

Digital Photograph Taken Yes X No \_\_\_\_\_ Photo # 88

Shelter/bench on private property or in right a way \_\_\_\_\_

Shelter Make, Model and Size \_\_\_\_\_

Cement Size 5'x4', 5'x31', 10'x15.5' Square Footage 427 Sq'

Special Remarks Demo 172 sq' of existing city walk, lower manhole cover to match new walk elevation replace with new drawing

#### Drawing Layout

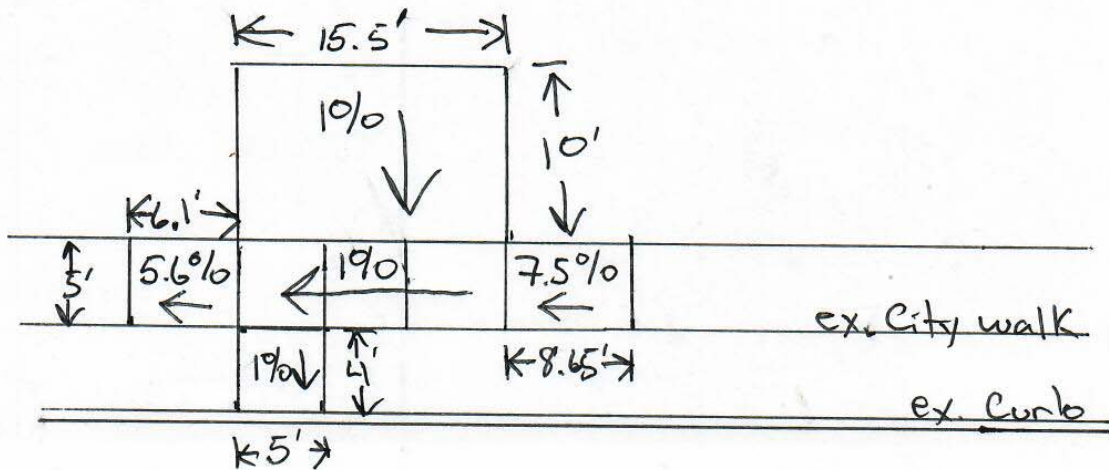

### BUS STOP INFORMATION

Date 4-8-25

Route 13 Inbound \_\_\_\_\_ Outbound \_\_\_\_\_ Trapeze ID 5740

GPS Latitude \_\_\_\_\_ Longitude \_\_\_\_\_ Capital Asset # \_\_\_\_\_

Nearest Crossroads \_\_\_\_\_

Landmark-Corner / direction from Intersection \_\_\_\_\_

Amenities at location

\_\_\_ New Bus Stop / Shelter \_\_\_ Service Mount Base \_\_\_ In-Ground Base \_\_\_

\_\_\_ Bench

\_\_\_ Ash Try

\_\_\_ Trash Receptacle / Pole Mount \_\_\_ 15 Gal \_\_\_ 30 Gal \_\_\_ 50 Gal \_\_\_

\_\_\_ Install Information Sign / Type \_\_\_\_\_ Quantity \_\_\_\_\_ Size \_\_\_\_\_

\_\_\_ Other / \_\_\_\_\_

Digital Photograph Taken Yes X No \_\_\_\_\_ Photo # 88

Shelter/bench on private property or in right a way \_\_\_\_\_

Shelter Make, Model and Size \_\_\_\_\_

Cement Size \_\_\_\_\_ Square Footage \_\_\_\_\_

Special Remarks \_\_\_\_\_

\_\_\_\_\_

\_\_\_\_\_

Drawing Layout

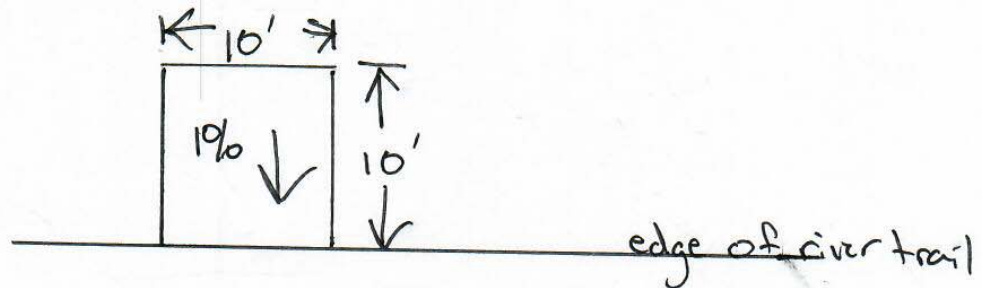



### BUS STOP INFORMATION

Date 4-8-25

Route 14 Inbound  Outbound \_\_\_\_\_ Trapeze ID 3789

GPS Latitude 42.752176 Longitude 81.553712 Capital Asset # \_\_\_\_\_

Nearest Crossroads W. North st, N. Washington ave

Landmark-Corner / direction from Intersection west

#### Amenities at location

New Bus Stop / Shelter  Service Mount Base  In-Ground Base \_\_\_\_\_

Bench

Ash Try

Trash Receptacle / Pole Mount \_\_\_\_\_ 15 Gal \_\_\_\_\_ 30 Gal \_\_\_\_\_ 50 Gal \_\_\_\_\_

Install Information Sign / Type \_\_\_\_\_ Quantity \_\_\_\_\_ Size \_\_\_\_\_

Other / \_\_\_\_\_

Digital Photograph Taken Yes  No \_\_\_\_\_ Photo # 89

Shelter/bench on private property or in right a way \_\_\_\_\_

Shelter Make, Model and Size \_\_\_\_\_

Cement Size \_\_\_\_\_ Square Footage 421 Sq'

Special Remarks Demo 125 Sq' of existing walk replace with new drawings

#### Drawing Layout

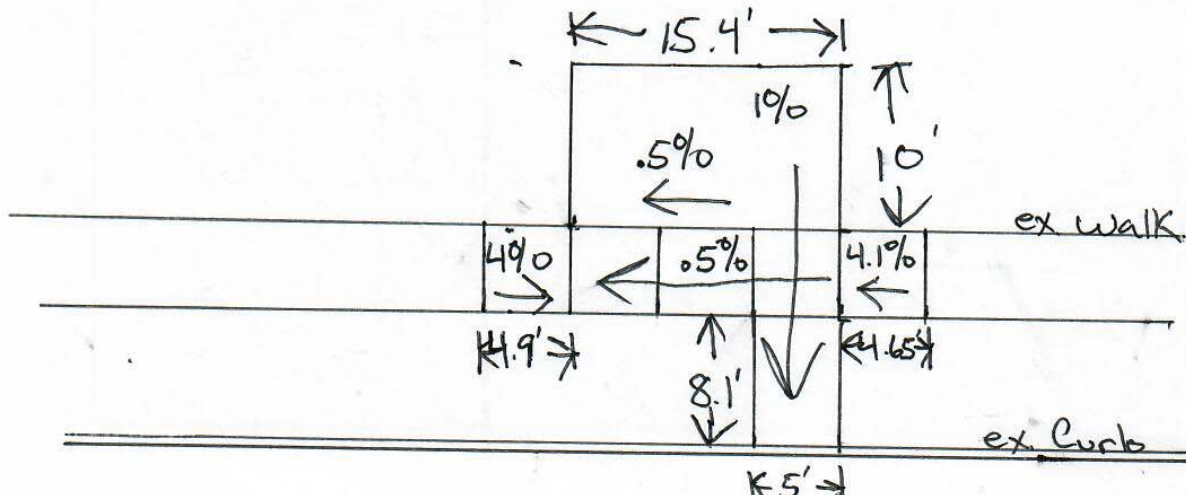

### BUS STOP INFORMATION

Date 4-8-25

Route 14 Inbound \_\_\_\_\_ Outbound \_\_\_\_\_ Trapeze ID 3789

GPS Latitude \_\_\_\_\_ Longitude \_\_\_\_\_ Capital Asset # \_\_\_\_\_

Nearest Crossroads \_\_\_\_\_

Landmark-Corner / direction from Intersection \_\_\_\_\_

Amenities at location

New Bus Stop / Shelter  Service Mount Base  In-Ground Base

Bench

Ash Try

Trash Receptacle / Pole Mount \_\_\_\_\_ 15 Gal \_\_\_\_\_ 30 Gal \_\_\_\_\_ 50 Gal \_\_\_\_\_

Install Information Sign / Type \_\_\_\_\_ Quantity \_\_\_\_\_ Size \_\_\_\_\_

Other / \_\_\_\_\_

Digital Photograph Taken Yes  No \_\_\_\_\_ Photo # 89

Shelter/bench on private property or in right a way \_\_\_\_\_

Shelter Make, Model and Size \_\_\_\_\_

Cement Size \_\_\_\_\_ Square Footage \_\_\_\_\_

Special Remarks \_\_\_\_\_

\_\_\_\_\_

\_\_\_\_\_

\_\_\_\_\_

Drawing Layout

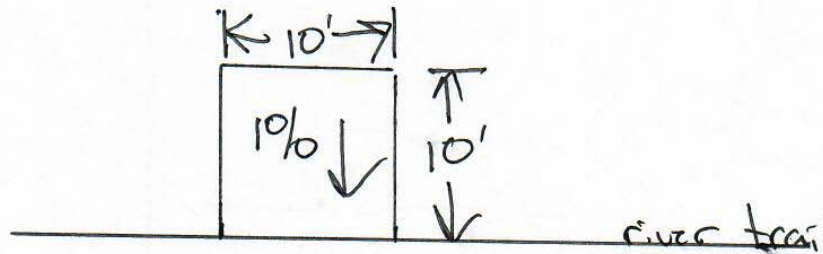



ATTACHMENT B

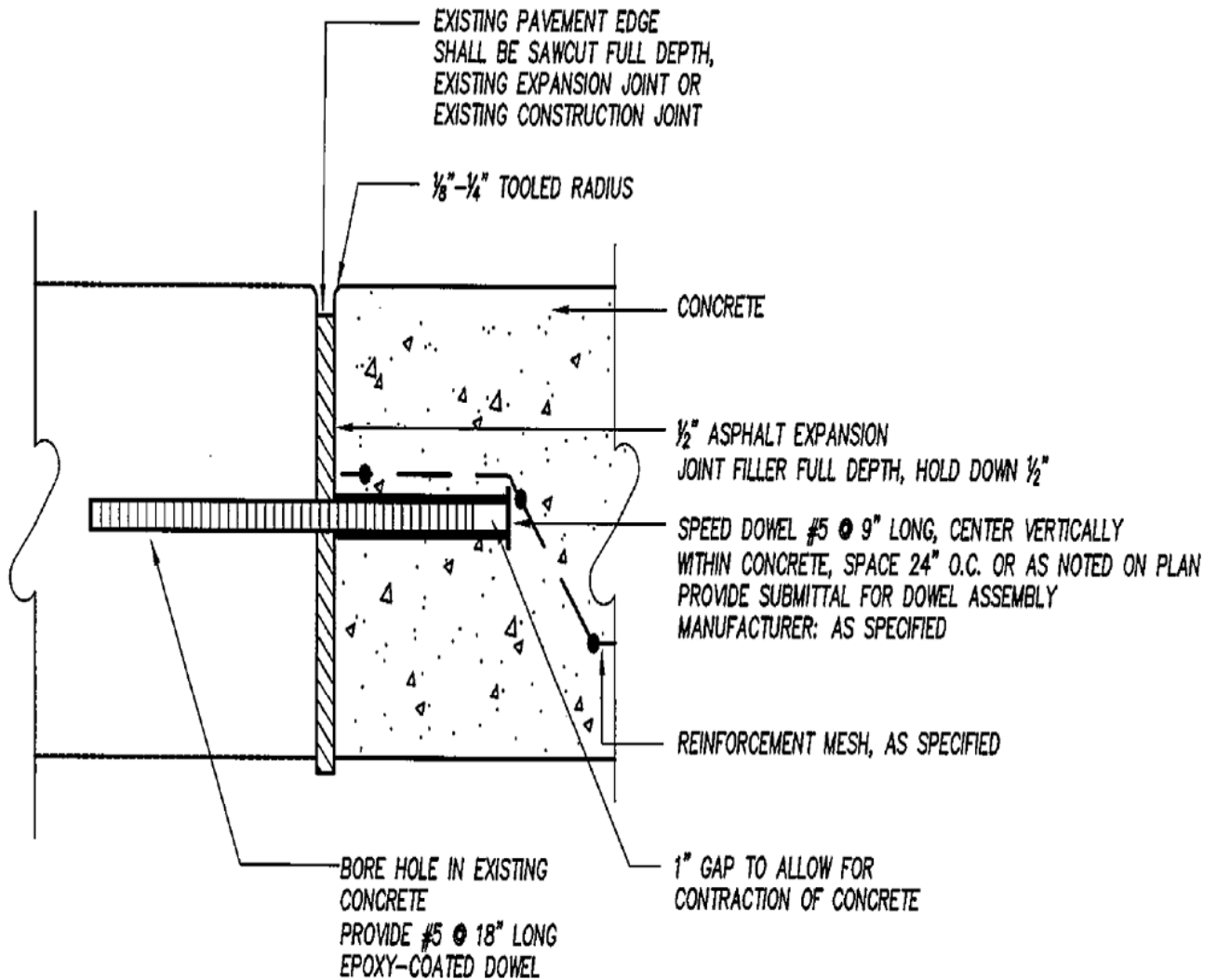

**X** EXPANSION JOINT AT EXISTING PAVEMENT  
**X-X** SCALE: 3"=1'-0"

END OF THIS SECTION

**EXHIBIT B  
PRICING SCHEDULE**

Please show the price to perform the following:

Stop ID #	Location	Description	Cost / Location Total
1990	NBD Cedar St, E. Elm St. Lansing, MI 48912	Pad Cost & Fees: Labor & Materials	\$
		Trip Charges, Truck Charges, Other Charges, Permits	\$
5740	EBD N. Grand Ave, E. Saginaw St. Lansing, MI 48933	Pad Cost & Fees: Labor & Materials	\$
		Trip Charges, Truck Charges, Other Charges, Permits	\$
3789	WBD W. North St., N. Washington Ave Lansing, MI 48906	Pad Cost & Fees: Labor & Materials	\$
		Trip Charges, Truck Charges, Other Charges, Permits	\$
<b>GRAND TOTAL:</b>		<b>\$</b>	

Bidder: \_\_\_\_\_

Signature: \_\_\_\_\_

Printed Name: \_\_\_\_\_

Title: \_\_\_\_\_

Date: \_\_\_\_\_

### EXHIBIT C SUBMITTAL CHECKLIST

Deadline: June 4, 2025, by 11:00 A.M. Eastern Time *(A quote will be automatically rejected if it is received after the stated deadline.)*

**All forms/certifications below MUST be completed and included when you submit your quote package.**

**Failure to submit the requested documents could result in determining the submission as non-responsive and rejected.**

- Signed and completed Pricing Schedule Form
- Signed and completed Submittal Checklist Form
- Signed Iran Economic Sanctions Act Certificate
- Signed and completed Offer and Guarantees
- Signed Certification of Primary Contractor Regarding Debarment & Suspension
- Signed Certification of Lower-Tier Participants (Sub-Contractors) Regarding Debarment & Suspension (if applicable)
- Signed and completed Bidders List Data Form
- Signed and completed Amendment(s) (as issued)
- 5% Bid Bond

**Please Note:** This bid package and any amendments are available at [www.cata.org](http://www.cata.org). Please continue checking the website for any updates or amendments.

**SUBMITTED QUOTE CONTAINS ALL COMPLETED FORMS/CERTIFICATIONS AS LISTED ABOVE**

Bidder: \_\_\_\_\_

Signature: \_\_\_\_\_

Printed Name: \_\_\_\_\_

Title: \_\_\_\_\_

Date: \_\_\_\_\_

**THIS FORM MUST BE COMPLETED AND RETURNED WITH YOUR OFFER**

**EXHIBIT D**  
**IRAN ECONOMIC SANCTIONS ACT CERTIFICATE**

---

In accordance with the Iran Economic Sanctions Act, Michigan 2012 PA 517, effective April 1, 2013, (MCL 129.311, *et seq.*), the undersigned certifies in support of its bid or proposal that it is not an Iran linked business as such is defined in the Act.

Bidder: \_\_\_\_\_

Signature: \_\_\_\_\_

Printed Name: \_\_\_\_\_

Title: \_\_\_\_\_

Date: \_\_\_\_\_

**THIS FORM MUST BE COMPLETED AND RETURNED WITH YOUR OFFER**

**EXHIBIT E**  
**OFFER and GUARANTEES**

By execution below, the Bidder hereby offers to furnish the items as described herein. The Bidder also certifies that it can and will provide and make available, at a minimum, the items set forth in this solicitation.

<b>FIRM'S NAME AND ADDRESS</b>		<b>PAYMENT REMITTANCE ADDRESS</b>	
<b>Name:</b>		<b>Name:</b>	
<b>Address:</b>		<b>Address:</b>	
<b>P.O. Box or Suite No.</b>		<b>P.O. Box or Suite No.</b>	
<b>City</b>		<b>City</b>	
<b>State</b>	<b>Zip</b>	<b>State</b>	<b>Zip</b>
<b>Contact Person:</b>			
<b>Telephone No.</b>	<b>Fax No.</b>	<b>E-Mail Address:</b>	
<b>FEDERAL EMPLOYER I.D. NUMBER:</b>		<b>SOCIAL SECURITY NUMBER:</b> (If Federal I.D. is not applicable)	
<b>Payment Terms:</b>		<b>Age of Firm:</b>	
<b>Disadvantaged Business Enterprise:</b> ( ) Yes            ( ) No If yes, attach the certificate from the certifying agency.			
<b>Minority Business Category:</b> ( ) Female ( ) Black ( ) Hispanic ( ) Asian American ( ) Indian/Alaskan Native ( ) Other ( ) Not Applicable			
<b>Annual Gross Receipts:</b> ( ) less than \$500,000 ( ) \$500,000 to \$1 million ( ) \$1 million to \$5 million ( ) greater than \$5 million			
<b>Contractor's License Type:</b>			
<b>Contractor's License Number:</b>			
<b>License Expiration Date:</b>			
<b>NAME OF BIDDER (Type or Print)</b>		<b>TITLE OF BIDDER</b>	
<b>Signature of Contractor's Authorized Official</b>		<b>(Date Signed)</b>	

**THIS FORM MUST BE COMPLETED AND RETURNED WITH YOUR OFFER**

**EXHIBIT F  
CERTIFICATION OF PRIMARY CONTRACTOR REGARDING DEBARMENT, SUSPENSION AND  
OTHER RESPONSIBILITY MATTERS**

The Primary Contractor, \_\_\_\_\_, certifies to the best of its knowledge and belief, that it and its principals:

- 1. Are not presently debarred, suspended, proposed for debarment, declared ineligible, or voluntarily excluded from covered transactions by any Federal department or agency;
- 2. Have not within a three (3) year period preceding this proposal been convicted of or had a civil judgment rendered against them for commission of fraud or a criminal offense in connection with obtaining, attempting to obtain, or performing a public (Federal, State or Local) transaction or contract under a public transaction; violation of Federal or State antitrust statutes or commission of embezzlement, theft, forgery, bribery, falsification or destruction of records, making false statements, or receiving stolen property;
- 3. Are not presently indicted for or otherwise criminally or civilly charged by a governmental entity (Federal, State, or Local) with commission of any of the offense enumerated in paragraph (2) of this certification; and
- 4. Have not within a three (3) year period preceding this application/proposal had one (1) or more public transactions (Federal, State, or Local) terminated for cause or default.

If the above-named Primary Contractor is unable to certify to any of the statements in this certification, the Primary Contractor shall attach an explanation to this certification.

The Primary Contractor, \_\_\_\_\_, certifies or affirms the truthfulness and accuracy of the contents of the statements submitted on or with this certification and understands that the provision of 31 U.S.C. Section 3801 et seq. are applicable thereto.

Bidder: \_\_\_\_\_

Signature: \_\_\_\_\_

Printed Name: \_\_\_\_\_

Title: \_\_\_\_\_

Date: \_\_\_\_\_

**EXHIBIT G  
CERTIFICATION OF LOWER-TIER PARTICIPANTS (SUB-CONTRACTORS) REGARDING  
DEBARMENT, SUSPENSION AND OTHER RESPONSIBILITY MATTERS**

**Debarment and Suspension Certification (Lower-Tier Covered Transaction)**

This form is to be submitted by each Subcontractor receiving an amount exceeding \$25,000.

The prospective lower-tier participant (Proposer) certifies, by submission of this Proposal, that neither it nor its "principals" as defined at 49 CFR § 29.105(p) is presently debarred, suspended, proposed for debarment, declared ineligible, or voluntarily excluded from participation in this transaction by any federal department or agency.

If the prospective Proposer is unable to certify to the statement above, it shall attach an explanation, and indicate that it has done so by placing an "X" in the following space: \_\_\_\_\_

**THE PROPOSER, \_\_\_\_\_, CERTIFIES OR AFFIRMS THE TRUTHFULNESS AND ACCURACY OF EACH STATEMENT OF ITS CERTIFICATION AND EXPLANATION, IF ANY. IN ADDITION, THE PROPOSER UNDERSTANDS AND AGREES THAT THE PROVISIONS OF 31 USC §§ 3801 ET SEQ. APPLY TO THIS CERTIFICATION AND EXPLANATION, IF ANY.**

**Name and title of the Proposer's authorized official:**

\_\_\_\_\_  
Authorized signature

\_\_\_\_\_  
Date

**THIS FORM MUST BE COMPLETED AND RETURNED WITH YOUR OFFER**

## EXHIBIT H BIDDERS LIST DATA FORM

CATA is required pursuant to 49 CFR Part 26(c) to create and maintain a comprehensive Bidders List. The information provided on this Bidders List Data Form will be used to determine the relative availability of Disadvantaged Business Enterprises (DBE's) and non-DBE's and will assist with establishing CATA's annual DBE goal. CATA's Bidders List is a compilation of bidders, proposers, quoters, sub-contractors, and suppliers of materials and services who have submitted bids during the advertising periods of a solicitation for services and/or goods.

Please provide the following information:

1. Firm Name: \_\_\_\_\_
2. Firm Address: \_\_\_\_\_  
\_\_\_\_\_
3. Firm Phone Number: \_\_\_\_\_
4. Name of firm's majority owner: \_\_\_\_\_
5. Title of firm's majority owner: \_\_\_\_\_
6. Race of firm's majority owner: \_\_\_\_\_
7. Gender of firm's majority owner: \_\_\_\_\_
8. Phone number of firm's majority owner: \_\_\_\_\_
9. Email address of firm's majority owner: \_\_\_\_\_
10. Age of Firm: \_\_\_\_\_ Years \_\_\_\_\_ Months
11. Provide North American Industry Classification System (NAICS) code(s) that best defines your firm:  
\_\_\_\_\_  
(NAICS code applicable to each scope of work the firm sought to perform in its bid)
12. Is the firm a certified DBE under Michigan's Department of Transportation (MDOT) Unified certification Program (UCP)? \_\_\_\_\_ Yes \_\_\_\_\_ No
13. For certified DBE's under the MDOT UPC is/are the NAICS code(s) above the NAICS code(s) which you are certified as a DBE? \_\_\_\_\_ Yes \_\_\_\_\_ No
14. Will the firm subcontract any work, service and/or materials? \_\_\_\_\_ Yes\* \_\_\_\_\_ No  
\*If yes, please have all subcontractor(s) complete their own Bidders List Data Form.
15. Firm's annual gross receipts:
  - Less than \$1 Million
  - \$1-3 Million
  - \$3-6 Million
  - \$6-10 Million
  - Over \$10 Million

Authorized Signature: \_\_\_\_\_ Date: \_\_\_\_\_

Printed Name: \_\_\_\_\_ Title: \_\_\_\_\_

**THIS FORM MUST BE COMPLETED AND RETURNED WITH YOUR OFFER**

## EXHIBIT I TERMS and CONDITIONS

### CAPITAL AREA TRANSPORTATION AUTHORITY

#### STANDARD TERMS AND CONDITIONS OF PROCUREMENT

1. **CHANGES.** CATA, at any time, by a written order, and without notice to the sureties, may make changes within the general scope of this contract, in (a) drawings, designs or specifications where the supplies to be furnished are specifically manufactured for CATA in accordance therewith; (b) method of shipment or packing; and (c) place of delivery. If any such change causes a substantial increase or decrease in the cost of, or the time required for performance of this contract, whether changed or not changed by such order, the parties shall agree to an equitable adjustment by written modification of the contract. If the parties cannot so agree, CATA shall have the option to terminate the contract. Any claim by the Contractor for adjustment under this clause must be asserted within thirty (30) days from the date of receipt by the Contractor of the notification of change.
2. **TERMINATION FOR DEFAULT.** CATA, by written notice, may terminate the contract, in whole or in part, for failure of the Contractor to perform any of the provisions of the contract. In such event, the Contractor shall be liable for all damages CATA incurs, including the excess cost of reprocurring similar supplies or services, provided, that if (a) it is determined for any reason that the Contractor was not in default or, (b) the Contractor's failure to perform is without his control, fault or negligence, the termination shall be deemed to be a termination for convenience under the following Paragraph 3.
3. **TERMINATION FOR CONVENIENCE.** CATA, by written notice, may terminate the contract, in whole or in part, for any reason when it determines it is in the best interest of CATA. If this contract is so terminated, the Contractor shall be compensated only for costs actually incurred and/or services actually performed prior to the time of notification of termination.
4. **TRANSITION RESPONSIBILITIES.** Upon termination of the contract for any reason, if CATA requests Contractor must reasonably assist with restoring CATA's data and/or materials to CATA and with any mandatory activities required for transition.
5. **ADDITIONAL INFORMATION.** The Contractor shall promptly furnish any additional information requested by CATA.
6. **CONTRACTOR RESPONSIBILITY.** The Contractor shall assume responsibility to ensure all materials used are suitable for CATA's needs whether the same is manufactured by the Contractor or purchased ready made from a source outside Contractor's company.
7. **DELIVERY.** Service and/or equipment will be delivered to Capital Area Transportation Authority, 4615 Tranter Street, Lansing, Michigan 48910. Invoices shall be furnished with the delivery of each item, service, or as otherwise specified in the contract. CATA reserves the right to inspect, but is not required to so inspect, all deliveries or services before acceptance.
8. **BREACH OF CONTRACT.** If the Contractor shall fail, refuse or neglect to comply with the terms of these contract conditions, such failure shall be deemed a total and material breach of the contract. Contractor shall be subject to all legal causes of actions, rights, and remedies that CATA may have and CATA may recover, in addition to any damages or costs relating to Contractor's breach, its reasonable attorneys' fees resulting from Contractor's breach.
9. **DISPUTES (AFTER BID AWARD).** Except as otherwise provided in the contract, any dispute concerning a question of fact arising under the contract which is not disposed of by agreement between CATA and Contractor shall be decided by CATA's Program Manager in writing, with a copy mailed or otherwise furnished to the Contractor. The decision of CATA shall be final and conclusive unless within ten (10) days from the date of receipt of such copy, the Contractor mails or otherwise furnishes to CATA a written appeal addressed to CATA's Chief Executive Officer for the determination of such appeal, which shall be final and conclusive, unless determined by a court of competent jurisdiction to have been fraudulent or capricious, or arbitrary, or so grossly erroneous as necessarily to imply bad faith, or not supported by substantial evidence. In connection with any appeal proceeding under this clause, the Contractor shall be afforded an opportunity to be heard and to offer evidence in support of its appeal. Pending a final decision of the dispute, the Contractor shall proceed diligently with the performance of the contract and in accordance with CATA's decision.
10. **DELIVERY EXTENSION AND DELAYS.** CATA reserves the right to extend, postpone or reschedule delivery in case the delivery of service equipment, under this contract, shall be necessarily delayed because of strike, injunction, civil disturbance, pandemic/endemic, force majeure, government controls, or by reason of any cause or circumstance beyond the control of the Contractor. In the event of such a delay, Contractor must notify CATA in writing. CATA shall reasonably extend the time of completion or a delivery by a number of days to be determined in each instance by CATA.
11. **INSTALLATION.** If specified in the contract, the Contractor shall install and place in operation, subject to approval by CATA, the equipment at the Contractor's expense within thirty (30) days from issuance of a notice to install issued by CATA.
12. **INSTALLATION EXTENSION AND DELAYS.** CATA reserves the right to extend, postpone, or reschedule installation in case the installation of equipment under this contract shall be necessarily delayed because of strike, injunction, civil disturbance, pandemic/endemic, force majeure, government controls, or by reason or cause or circumstances beyond the control of the Contractor. The time of completion or installation shall be extended by a reasonable number of days to be determined in each instance by CATA.
13. **ASSEMBLY.** If required for the equipment to be operational and suitable for CATA's purposes, the Contractor shall assemble the equipment at its expense prior to installation.

14. **ACCESSORIES.** The Contractor shall furnish, without additional cost, all accessories required to permit CATA to operate any equipment being provided.
15. **COMMUNICATION AND TRAINING.** Contractor shall confer as necessary and cooperate with CATA in order that the services performed under the contract may proceed in an efficient and satisfactory manner. Contractor's work will include all conferences, consultations, hearings, or appearances deemed necessary by CATA to ensure that Contractor will be able to properly and fully perform the objectives as set forth in the contract. The Contractor, without additional cost, shall properly train CATA personnel in the operation and maintenance of the equipment provided.
16. **SERVICE MANUAL AND WIRING SCHEMATIC.** If specified, the Contractor will provide at least one copy of a service manual and at least one copy of a wiring schematic for individual components and other schematics and drawings.
17. **WARRANTY.** Contractor unconditionally guarantees that the quality of its work and warrants all work, services, and equipment it performs and/or provides under the contract will meet or exceed CATA's requirements and expectations. In addition to any other warranty, Contractor shall perform all obligations under the contract in a satisfactory manner as shall be determined within the sole and reasonable discretion of CATA. If CATA is dissatisfied with the quality of Contractor's work or Contractor's performance under the contract for any reason, CATA shall provide written notice to Contractor. If Contractor fails to remedy any quality or performance issue within 30 days from the date of this written notice, CATA shall have the right to immediately terminate the contract with no further obligations to Contractor, financial or otherwise. The Contractor shall describe its policy or warranty(s) both on workmanship and material as applying to the equipment, along with the method or adjustment, and shall be further subject to warranty requirements of CATA as set forth in the following Paragraph 17. The Contractor agrees that the supplies or services furnished under this contract shall be covered by the most favorable warranties the Contractor gives any customer for such equipment and that the rights and remedies provided herein are in addition to and do not limit any rights afforded to CATA by any other clause of this contract.
18. **PERFORMANCE GUARANTY.** Contractor must at all times have financial resources sufficient, in the opinion of CATA to ensure performance of the contract and must provide proof upon request. CATA may require a performance bond if, in the opinion of the CATA, it is necessary to ensure performance of the contract. If required, as provided in federal regulations and modified by FTA guidance, for each Project or related activities implementing the Underlying Agreement that involve construction, it will provide bid guarantee bonds, contract performance bonds, and payment bonds.
19. **INSURANCE.** The Contractor shall place and maintain with responsible insurance carriers the following insurance. The Contractor shall deliver to CATA, upon request, certificates of insurance which shall provide thirty (30) days' written notice to be given to CATA in the event of cancellation. Contractor shall require all Subcontractors to maintain adequate insurance coverage.
- (a) Workers' Compensation and Employer's Liability Insurance.
- (1) Workers' Compensation in compliance with the applicable state and federal laws.  
(2) Employer's Liability. Limit \$1,000,000.
- (b) Commercial General Liability Insurance, including Professional Liability, Blanket contractual, XCU Hazards, Broad Form Property Damage, Completed Operations, and Independent Contractor's Liability, all applicable to Personal Injury, Bodily Injury and Property Damage to a combined single limit of \$1,000,000 each occurrence/claim, subject to a \$2,000,000 annual aggregate for Professional Liability, Completed Operations and Personal Injury other than Bodily Injury.
- (c) Automobile Liability Insurance, including owned, hired and non-owned automobiles, Bodily Injury and Property Damage, to a combined single limit of \$1,000,000 each occurrence.
- (d) Cyber Liability Insurance, to a combined single limit of \$1,000,000 each occurrence/claim.
- Occurrence-based policies must be maintained for the duration of the contract. Claims-made policies must be maintained for that period and until all applicable statutes of limitations have expired. Contractor's insurance must be primary so that any CATA insurance is excess, secondary, and non-contributing. Contractor agrees to name CATA as an additional insured on any applicable policies including, but not limited to the liability insurance policy, to provide the fullest insurance and indemnification to CATA allowed by the policy and applicable law. Contractor's insurance must be written by carrier's authorized to write insurance in Michigan and having at least an A- rating in the most recently published version of A.M. Best Company Insurance Ratings. Contractor's insurance must be endorsed to provide that the policy will not be canceled or materially changed without 30 days written notice to CATA (or if this endorsement cannot be obtained, Contractor will give CATA at least 30 days' advance notice before any policy is cancelled or its terms are materially altered). Each of Contractor's insurance policies must waive all of their subrogation rights with respect to losses payable under the policy.
- Contractor must provide a copy of its insurance policies complying with the terms of the contract to CATA if CATA so requests. CATA is under no obligation to request such policies.

20. **INDEMNIFICATION, HOLD HARMLESS, DEFENSE, AND WAIVER OF CLAIMS.** While insurance can be used to satisfy this obligation, not limited by the protection afforded by any policy of insurance, to the fullest extent permitted by law Contractor agrees to indemnify, defend, and hold harmless CATA and, if applicable, the Michigan Department of Transportation, the Federal Transit Administration, and all of each of their officers, agents, and employees thereof, without reservation, from and against any and all liabilities, obligations, penalties, claims, charges, demands, causes of action, losses, damages, costs and expenses, whether determined to be valid or only alleged, in any way related to Contractor's obligations and/or performance of the contract including, but not limited to: (a) any breach by Contractor (or any

of Contractor's employees, agents, subcontractors, or by anyone else for whose acts any of them may be liable) of any of the promises, agreements, representations, warranties, or insurance requirements contained in the contract; (b) any infringement, misappropriation, or other violation of any intellectual property right or other right of any third party; (c) any bodily injury, death, or damage to real or tangible personal property occurring wholly or in part due to action or inaction by Contractor (or any of Contractor's employees, agents, subcontractors, or by anyone else for whose acts any of them may be liable); and (d) any acts or omissions of Contractor (or any of Contractor's employees, agents, subcontractors, or by anyone else for whose acts any of them may be liable).

CATA shall promptly notify Contractor of any claim as to which it seeks defense and indemnification and provide reasonable cooperation. Contractor shall have the right to select counsel and to control the defense, so long as CATA consents and agrees to the counsel, such approval within the sole discretion of CATA.

To the fullest extent permitted by law, Contractor hereby waives any and all claims against CATA and agrees not to hold CATA liable for any damages including, but not limited to, personal injury or property damage incurred by Contractor or its employees while performing services under the contract.

21. CATA will not be subject to any obligations or liabilities by Subcontractors of the Contractor or their Subcontractors or any other person not a party to this contract without its specific consent and notwithstanding its concurrence in or approval of the award of any contract or subcontract or the solicitation thereof.
22. **ACCEPTANCE OF MATERIAL - NO RELEASE.** Unless CATA otherwise agrees in writing, acceptance of any portion of the material prior to final acceptance shall not release the Contractor from liability for faulty workmanship or materials or for failure to fully comply with all of the terms of this contract. CATA reserves the right and shall be at liberty to inspect all materials and workmanship at any time during the manufacturing process, and shall have the right to reject all materials and workmanship which do not conform with the contract requirements and specifications; provided, however, that CATA is under no duty to make such inspection and no inspection so made shall relieve Contractor from any obligation to furnish materials and workmanship in accordance with the contract requirements and specifications.
23. **FINAL ACCEPTANCE.** All services performed by Contractor under the contract are subject to review and approval of CATA for completeness and fulfillment of the requirements of the contract. CATA's review, approval, or payment for any services shall never be construed to operate as a waiver of any rights under the contract, and Contractor shall be and will remain liable in accordance with applicable law for all damages to CATA caused by Contractor's negligent performance or nonperformance of any services furnished under the contract or any representations made under or in performance of the contract. Final undisputed payment for services or equipment under the contract shall commence the warranty period.
24. **NO ASSIGNMENT OF CONTRACT.** The contract is only with Contractor and may not be assigned by Contractor to any other person or entity without CATA's written consent. Any assignment in violation of this paragraph shall be void and shall provide the opportunity to CATA to void the contract, at its sole choice and election.
25. **DEFECTIVE WORKMANSHIP AND MATERIAL.** When and as often as CATA determines that the work done or being done under the contract or the kind of quality or materials supplied in connection therewith are not fully and completely in accordance with any requirement of the contract documents, it may give notice of such noncompliance to the Contractor in writing and the Contractor shall immediately upon receipt of such notice do all things required to remedy such noncompliance without additional cost to CATA. If the Contractor fails to comply with such written notice, then CATA, upon written notice to the Contractor, shall deduct the cost of repair, replacement or correction of defective or damaged work from the compensation due or to become due to the Contractor, or terminate the contract in its sole discretion.
26. **WAIVER.** No failure by CATA to insist upon the strict performance of any covenant, duty, obligation, agreement, or condition of the contract or to exercise any right or remedy consequent upon a breach thereof shall constitute waiver of any such breach of any other covenant, duty, obligation, agreement, or condition. Neither the assessment of liquidated damages or penalties nor any failure to assess liquidated damages or penalties shall be construed to waive or excuse performance requirements or any rights CATA has to damages or penalties under the contract
27. **CONFIDENTIALITY AND OWNERSHIP OF DATA AND DOCUMENTS.**
  - (a) All original documents, calculations, and work product produced by Contractor, whether produced on paper or electronic media or otherwise in performance of the contract, and all data gathered through provision of services shall be the sole and exclusive property of CATA. Contractor shall make available to CATA copies of all Contractor correspondence, notes, and other papers relating to the work, upon request of CATA. All works of original authorship created in the scope of the contract are "works made for hire," as that term is used in connection with the U.S. Copyright Act.
  - (b) To the extent that by operation of law Contractor retains any intellectual property rights to any work product, Contractor hereby irrevocably assigns and licenses to CATA all right, title, and interest in such work product, including copyrights and patents, and agrees to execute such assignments and licenses as may be required in the opinion of CATA's legal counsel to confirm this provision.
  - (c) To the extent that the work product produced by Contractor contains standard design or construction details or other standardized material previously developed by Contractor in its professional practice, then Contractor shall have the right to reuse any such material on other projects for other clients or persons without the prior knowledge or permission of CATA and without the payment

of any compensation to CATA, provided that the reuse or continued use of such material contains no CATA identifying information or confidential information.

- (d) In order that the Contractor may effectively fulfill its obligations under the contract, it may be necessary or desirable for CATA to disclose confidential and/or proprietary information to the Contractor. Since it is difficult to separate confidential and proprietary information from that which is not, the Contractor shall regard, and shall instruct its employees to regard, all information gained from CATA as confidential and such information shall not be disclosed to any organization or individual without court order or the prior written consent of CATA. With respect to a subpoena, court order or other legal process, Contractor shall notify CATA of the demand for information before responding, and shall comply with this provision to the extent practicable. The above obligation shall not apply to information already in the public domain or information required to be disclosed by a court order. Contractor agrees to take appropriate action with respect to its employees to ensure that the foregoing obligations of non-use and non-disclosure of confidential information shall be fully satisfied.
- (e) PATENT RIGHTS. Contractor agrees that:
- a. (1) Depending on the nature of the Underlying Agreement, the Federal Government may acquire patent rights when the Contractor produces a patented or patentable invention, improvement, or discovery; (2) The Federal Government's rights arise when the patent or patentable information is conceived or reduced to practice with federal assistance provided through the Underlying Agreement; or (3) When a patent is issued or patented information becomes available as described in the preceding section 17(a)(2) of this Master Agreement, the Contractor will notify FTA immediately and provide a detailed report satisfactory to FTA.
  - b. Federal Rights. Contractor agrees that: (1) Its rights and responsibilities in that federally assisted invention, improvement, or discovery will be determined as provided in applicable federal laws, regulations, requirements, and guidance, including any waiver thereof; and (2) Unless the Federal Government determines otherwise in writing, irrespective of its status or the status of Contractor as a large business, small business, state government, state instrumentality, local government, Indian tribe, nonprofit organization, institution of higher education, or individual, the Contractor will transmit the Federal Government's patent rights to FTA, as specified in 35 U.S.C. § 200, et seq., and U.S. Department of Commerce regulations, "Rights to Inventions Made by Nonprofit Organizations and Small Business Firms Under Government Grants, Contracts and Cooperative Agreements," 37 CFR Part 401.
  - c. License Fees and Royalties. Consistent with the applicable U.S. DOT Common Rules, the Contractor agrees that license fees and royalties for patents, patent applications, and inventions produced with federal assistance provided through the Underlying Agreement are program income, and must be used in compliance with applicable federal requirements.

28. COMPUTATION OF TIME. In computing a period of time prescribed by these conditions, the following rules apply:

- (a) "Day" means days of the week (e.g., Monday through Friday), not business days.
- (b) The day of the act or event after which the designated period of time begins is not included.
- (c) The last day of the period is included, unless it is a Saturday, Sunday, or legal holiday. In that event, the period runs until the end of the next day that is not a Saturday, Sunday or legal holiday.

29. JURISDICTION. This Contract will be governed by the internal laws of the State of Michigan without reference to its choice of law rules. Exclusive jurisdiction and venue of any suit, action or claim relating to this contract will be in the Ingham County Circuit Court or the Federal District Court for the Western District of Michigan.

30. COST COMPUTATION. The Federal Acquisition Regulation, 48 CFR, Chapter 1, Part 31.2, as now existing or hereinafter amended, shall be used, in all instances, to determine the amount of costs incurred by Contractor that CATA shall be required to pay, or reimburse, to Contractor, including, without limitation, where the contract requires CATA to pay Contractor's costs as part of the contract price, where the contract price is adjusted resulting from changes to the requirements of the contract, and when calculating the amount due Contractor pursuant to Termination for Convenience clause.

31. TRAVEL EXPENSES. CATA shall not reimburse Contractor for travel costs, including accommodations, meals, transportation and fuel costs, unless the travel activity and the travel costs have been approved in advance by an authorized representative of CATA. All travel costs to be paid by CATA shall not exceed amounts determined in conformance with the Federal Acquisition Regulation, 48 CFR Section 31.205-46, Travel Costs.

32. EXTENSION. CATA has the right, in its sole discretion, to extend the term of the contract beyond the term and subsequent options outlined in the contract. Any such extension after the options outlined above must be in writing and upon terms mutually agreed between CATA and Contractor.

33. TIME IS OF THE ESSENCE. Contractor agrees time is of the essence in the performance of the contract. Failure to perform as required may, in CATA's sole discretion, be declared a material breach of contract.

34. **CONTRACTOR EMPLOYEES.** Contractor warrants and represents that its employees who will perform work under the contract are properly educated, trained and/or licensed to perform the services under the contract. Contractor shall perform all its obligations under the contract without the use of a subcontractor, unless CATA grants express written approval for the use of a subcontractor before such services are performed. Approval of a subcontractor is in CATA's sole discretion and is not required under any circumstance. In the event any such subcontractor is approved, Contractor's invoices and subcontractor receipts/invoices should clearly show that no mark-up costs, commissions or sales taxes were incurred. CATA will not pay mark-up or tax on any outside services which are obtained by Contractor.
35. **INDEPENDENT CONTRACTOR.** Contractor's relationship to CATA is independent-contractor-to-client. None of Contractor's personnel are employees of CATA, and CATA is not a partner of Contractor. Contractor expressly acknowledges and agrees that it and its employees are not and will not for any purposes be considered employees, agents, or representatives of CATA. Contractor shall be responsible for any and all taxes, worker's compensation insurance, and any other work-related expenses, including but not limited to work performed under contract for CATA. Contractor shall be solely responsible for the actions of its employees and/or contractors and agrees to fully defend, indemnify, and hold CATA harmless, without reservation for any claims or causes of action which arise as a result of their actions.
36. **MEDIA CONTACT AND RELEASES.** Contractor will not issue any public announcement or media release of any kind regarding the contract, the services performed or additional services or projects which relate to the contract, or any incident that occurs while performing services under the contract without the prior written approval of CATA, and then only to the extent of and in accordance with instructions given with such approval. CATA will be responsible for providing all public information materials on the services performed under the contract.
37. **INVOICING.** CATA shall not incur any expense until and only to the extent that services are provided by Contractor and such services are properly invoiced. If Contractor satisfactorily performs the required work under the contract. CATA will pay Contractor for the work performed as outlined in the Proposal, if the same is properly invoiced. Contractor is responsible to submit a complete, proper, and timely invoice to CATA for any orders under the contract. Failure to do so will relieve CATA of the obligation to pay. Each invoice must include invoice number, time period covered by the invoice, description of work completed, contact person and phone number, and payment remit address. CATA will pay each undisputed invoice within 30 days after receipt if that invoice meets the itemization and other requirements described in the contract. CATA may withhold from one or more invoices all amounts disputed in reasonable detail by CATA within 90 days of the date of invoice. Payment does not waive claims that CATA may have against Contractor. Contractor must continue to provide services regardless of any fee, price, or charge dispute.
38. **INTERPRETATION.**
- (a) References to laws, documents and other written materials include amendments that may be made from time to time.
  - (b) References to days mean calendar days. Any deadline or end of any time period that does not fall on a business day extends through the next business day. Business day means any calendar day other than a Saturday, Sunday or other day on which financial institutions close.
  - (c) If any provision of these General Terms and Conditions conflicts with a provision required by law or contract, including, but not limited to those mandated by MDOT, FTA, US DOT, or other mandatory provision, the mandatory provision shall prevail.
39. **RISK OF LOSS.** Until final acceptance, title and risk of loss or damage to any materials remains with Contractor. Contractor is responsible for filing, processing, and collecting all damage claims. CATA will record and report to Contractor any evidence of visible damage. If the CATA rejects any equipment or materials, Contractor must remove them from the premises within 10 calendar days after notification of rejection. The risk of loss of rejected or non-conforming equipment or materials remains with Contractor. Rejected equipment or materials not removed by Contractor within 10 calendar days will be deemed abandoned by Contractor, and CATA will have the right to dispose of it as its own property. Contractor must reimburse CATA for costs and expenses incurred in storing or effecting removal or disposition of rejected equipment or materials.
40. **SURVIVAL.** The provisions of the contract that impose continuing obligations, including warranties and representations, termination, transition, insurance coverage, indemnification, and confidentiality, will survive the expiration or termination of the contract.
41. **DISCLOSURE.** Contractor specifically and expressly understands that CATA is subject to public disclosures including the Freedom of Information Act and as such the contents of any contract with CATA, any information Contractor provides to CATA, payments made to Contractor, etc. may be disclosed by CATA without any prior notice to Contractor.
42. **COMPLIANCE WITH GRANT TERMS.** Contractor understands and agrees that CATA's funding to pay Contractor compensation for the contract may come from grant dollars or funding sources that have terms which need to be met. Contractor agrees that upon notification by CATA of these terms, Contractor will conduct itself in accordance with and abide by any such terms, without condition, to ensure CATA does not lose the funding source.
- a. Contractor agrees that the Federal Government may suspend, suspend then terminate, or terminate all or any part of the federal assistance for the Award if: (1) CATA or Contractor has failed to make reasonable progress implementing the Award; (2) The Federal Government determines that continuing to provide federal assistance to support the Award does not adequately serve the purposes of the law authorizing the Award; or (3) CATA or Contractor has violated the terms of the Underlying Agreement, especially if that violation would endanger substantial performance of the Underlying Agreement.
  - b. **Financial Implications.** In general, termination of federal assistance for the Award will not invalidate obligations properly incurred before the termination date to the extent that those obligations cannot be canceled. The Federal Government may recover the federal assistance it has provided for the Award, including the federal assistance for obligations properly incurred before the

termination date, if it determines that CATA or Contractor has misused its federal assistance by failing to make adequate progress, failing to make appropriate use of the Project property, or failing to comply with the Underlying Agreement, and require CATA or Contractor to refund the entire amount or a lesser amount, as the Federal Government may determine including obligations properly incurred before the termination date.

- c. Expiration of the Period of Performance. Except for a Full Funding Grant Agreement, expiration of any period of performance established for the Award does not, by itself, constitute an expiration or termination of the Award; FTA may extend the period of performance to assure that each Formula Project or related activities and each Project or related activities funded with "no year" funds can receive FTA assistance to the extent FTA deems appropriate.
- d. Uniform Administrative Requirements. These termination rights are in addition to and in no way limit the Federal Government's rights to terminate described in 2 CFR § 200.340.

43. MDOT AND FTA TERMS. All contractual provisions that the Michigan Department of Transportation ("MDOT"), the Federal Transit Administration ("FTA"), and/or the US Department of Transportation ("US DOT") by law or regulation, require to be included in contracts supported by state or federal financial assistance, including the requirements set forth in FTA Circular 4220.1 and the Clause Matrix (last updated September 2023), as updated and amended, and the Master Agreement between CATA and FTA and the Master Agreement between CATA and MDOT as it may be amended, all of which are hereby incorporated by reference. FTA required terms and MDOT required terms shall be deemed to control in the event of a conflict with other provisions contained in this contract. Contractor shall not refuse to comply with any CATA request to conform this contract to include MDOT or FTA required contractual provisions. The Contractor shall not perform any act, fail to perform any act, or refuse to comply with any CATA requests which would cause CATA to be in violation of the mandated contractual provisions.

44. FEDERALLY ASSISTED CONSTRUCTION CONTRACTS. Pursuant to the FTA Master Agreement, Section 16, Paragraph (4):

During the performance of this contract, the contractor agrees as follows:

- (1) The contractor will not discriminate against any employee or applicant for employment because of race, color, religion, sex, sexual orientation, gender identity, or national origin. The contractor will take affirmative action to ensure that applicants are employed, and that employees are treated during employment without regard to their race, color, religion, sex, sexual orientation, gender identity, or national origin. Such action shall include, but not be limited to the following: Employment, upgrading, demotion, or transfer; recruitment or recruitment advertising; layoff or termination; rates of pay or other forms of compensation; and selection for training, including apprenticeship. The contractor agrees to post in conspicuous places, available to employees and applicants for employment, notices to be provided setting forth the provisions of this nondiscrimination clause.
- (2) The contractor will, in all solicitations or advertisements for employees placed by or on behalf of the contractor, state that all qualified applicants will receive consideration for employment without regard to race, color, religion, sex, sexual orientation, gender identity, or national origin.
- (3) The contractor will not discharge or in any other manner discriminate against any employee or applicant for employment because such employee or applicant has inquired about, discussed, or disclosed the compensation of the employee or applicant or another employee or applicant. This provision shall not apply to instances in which an employee who has access to the compensation information of other employees or applicants as a part of such employee's essential job functions discloses the compensation of such other employees or applicants to individuals who do not otherwise have access to such information, unless such disclosure is in response to a formal complaint or charge, in furtherance of an investigation, proceeding, hearing, or action, including an investigation conducted by the employer, or is consistent with the contractor's legal duty to furnish information.
- (4) The contractor will send to each labor union or representative of workers with which he has a collective bargaining agreement or other contract or understanding, a notice to be provided advising the said labor union or workers' representatives of the contractor's commitments under this section, and shall post copies of the notice in conspicuous places available to employees and applicants for employment.
- (5) The contractor will comply with all provisions of Executive Order 11246 of September 24, 1965, and of the rules, regulations, and relevant orders of the Secretary of Labor.
- (6) The contractor will furnish all information and reports required by Executive Order 11246 of September 24, 1965, and by rules, regulations, and orders of the Secretary of Labor, or pursuant thereto, and will permit access to his books, records, and accounts by the administering agency and the Secretary of Labor for purposes of investigation to ascertain compliance with such rules, regulations, and orders.
- (7) In the event of the contractor's noncompliance with the nondiscrimination clauses of this contract or with any of the said rules, regulations, or orders, this contract may be canceled, terminated, or suspended in whole or in part and the contractor may be declared ineligible for further Government contracts or federally assisted construction contracts in accordance with procedures authorized in Executive Order 11246 of September 24, 1965, and such other sanctions may be imposed and remedies invoked as provided in Executive Order 11246 of September 24, 1965, or by rule, regulation, or order of the Secretary of Labor, or as otherwise provided by law.
- (8) The contractor will include the portion of the sentence immediately preceding paragraph (1) and the provisions of paragraphs (1) through (8) in every subcontract or purchase order unless exempted by rules, regulations, or orders of the Secretary of Labor issued pursuant to section 204 of Executive Order 11246 of September 24, 1965, so that such provisions will be binding upon each subcontractor or vendor. The contractor will take such action with respect to any subcontract or purchase order as the administering agency may direct as a means

of enforcing such provisions, including sanctions for noncompliance: Provided, however, that in the event a contractor becomes involved in, or is threatened with, litigation with a subcontractor or vendor as a result of such direction by the administering agency, the contractor may request the United States to enter into such litigation to protect the interests of the United States. The applicant further agrees that it will be bound by the above equal opportunity clause with respect to its own employment practices when it participates in federally assisted construction work: Provided, That if the applicant so participating is a State or local government, the above equal opportunity clause is not applicable to any agency, instrumentality or subdivision of such government which does not participate in work on or under the contract. The applicant agrees that it will assist and cooperate actively with the administering agency and the Secretary of Labor in obtaining the compliance of contractors and subcontractors with the equal opportunity clause and the rules, regulations, and relevant orders of the Secretary of Labor, that it will furnish the administering agency and the Secretary of Labor such information as they may require for the supervision of such compliance, and that it will otherwise assist the administering agency in the discharge of the agency's primary responsibility for securing compliance. The applicant further agrees that it will refrain from entering into any contract or contract modification subject to Executive Order 11246 of September 24, 1965, with a contractor debarred from, or who has not demonstrated eligibility for, Government contracts and federally assisted construction contracts pursuant to the Executive Order and will carry out such sanctions and penalties for violation of the equal opportunity clause as may be imposed upon contractors and subcontractors by the administering agency or the Secretary of Labor pursuant to Part II, Subpart D of the Executive Order. In addition, the applicant agrees that if it fails or refuses to comply with these undertakings, the administering agency may take any or all of the following actions: Cancel, terminate, or suspend in whole or in part this grant (contract, loan, insurance, guarantee); refrain from extending any further assistance to the applicant under the program with respect to which the failure or refund occurred until satisfactory assurance of future compliance has been received from such applicant; and refer the case to the Department of Justice for appropriate legal proceedings.

45. ETHICS. Contractor agrees it has or it will establish and maintain written Standards of Conduct covering conflicts of interest that:

- (1) Apply to the following individuals who have a present or potential financial interest, or other significant interest, such as a present or potential employment interest in the selection, award, or administration of a third party contract or subcontract: (i) The Recipient or its Subrecipients' officers, employees, board members, or agents engaged in the selection, award, or administration of any third party agreement; (ii) The immediate family members or partners of those listed above in section 4(a)(1)(i) of this Master Agreement; and (iii) An entity or organization that employs or is about to employ any person that has a relationship with the Recipient or its Subrecipient listed above in sections 4(a)(1)(i) and (ii) of this Master Agreement;
- (2) Prohibit those individuals listed above from: (i) Engaging in any activities involving the Recipient's or any of its Subrecipients' present or potential Third Party Participants at any tier, including selection, award, or administration of a third party agreement in which the individual has a present or potential financial or other significant interest; and (ii) Accepting a gratuity, favor, or anything of monetary value from a present or potential Third Party Participant in the Recipient's Underlying Agreement, unless the gift is unsolicited and has an insubstantial financial or nominal intrinsic value; and
- (3) Establish penalties, sanctions, or other disciplinary actions for violations, as permitted by state or local law or regulations, that apply to those individuals listed above for violations.

46. CHANGE IN CONTROL. Contractor will notify CATA within 30 days of any public announcement or otherwise once legally permitted to do so, of a material change in Contractor's organizational structure or ownership. For purposes of the contract, a material change in control means any of the following: (a) a sale of more than 50% of Contractor's stock; (b) a sale of substantially all of Contractor's assets; (c) a change in a majority of Contractor's board members; (d) consummation of a merger or consolidation of Contractor with any other entity; (e) a change in ownership through a transaction or series of transactions; (f) or the board (or the stockholders) approves a plan of complete liquidation. A change of control does not include any consolidation or merger effected exclusively to change the domicile of Contractor, or any transaction or series of transactions principally for bona fide equity financing purposes. In the event of a change of control, Contractor must require the successor to assume this Contract and all of its obligations under this Contract. If CATA is not satisfied for any reason with the new control, CATA has the option to terminate the contract.

47. CHANGE IN CIRCUMSTANCES. Contractor agrees that changed circumstances may occur that may impact CATA's ability to comply with the FTA terms and conditions such as: (i) A change in federal requirements or guidance; (ii) A change in state, territorial, local, or tribal requirements; (iii) A change in CATA or Contractor's circumstances, including: (A) Its legal, financial, technical, or managerial capacity; (B) Its continuing control of Project property; or (C) Another similar situation; and (iv) Any current or prospective legal matter with potentially serious consequences, including a major dispute, default, breach, or litigation, or knowledge that the Contractor's principal, official, employee, agent, or another third party, or other person has submitted a false claim under the False Claims Act, 31 U.S.C. § 3729, et seq., or has committed a criminal or civil violation of law pertaining to fraud, conflict of interest, bribery, gratuity, or similar misconduct involving federal assistance; suspension, debarment, or other similar administrative or enforcement action against CATA or the Contractor; or any matter or situation, including any other change or legal action that may adversely affect the Federal Government's interest in a Project or related activities. In the circumstances described above, Contractor agrees to provide immediate written notice to CATA so it can provide appropriate notice to the interested parties.

48. NOTICE OF DISPUTES, BREACHES, DEFAULTS, AND LITIGATION. If a current or prospective legal matter that may affect CATA or the federal government emerges, the Contractor must notify CATA. The Contractor must include a similar notification requirement in each of its subcontracts for twenty-five thousand dollars (\$25,000) or more.

- (a) Legal disputes that require notification under this provision include, but are not limited to, a major dispute, breach, default, litigation, or naming CATA or naming the federal government as a party to litigation or a legal disagreement in any forum for any reason.

- (b) Matters that may affect the federal government (and thereby CATA) include, but are not limited to, the or the federal government's interests in the award, the accompanying underlying agreement, and any amendments thereto, or the federal government's administration or enforcement of federal laws, regulations, and requirements.
- (c) Additional notice to U.S. DOT Inspector General. The Contractor must promptly notify the U.S. DOT Inspector General in addition to the FTA chief counsel or regional counsel for FTA's appropriate region, if the Contractor has knowledge of potential fraud, waste, or abuse occurring on a project receiving assistance from FTA. The notification provision applies if a person has or may have submitted a false claim under the false claims act, 31 U.S.C. § 3729, et seq., or has or may have committed a criminal or civil violation of law pertaining to such matters as fraud, conflict of interest, bid rigging, misappropriation or embezzlement, bribery, gratuity, or similar misconduct involving federal assistance. This responsibility occurs whether the project is the subject of this contract, another contract funded by the FTA, or an agreement involving a principal, officer, employee, or agent of the Contractor. It also applies to subcontractors at any tier. Knowledge, as used in this paragraph, includes, but is not limited to, knowledge of a criminal or civil investigation by a federal, state, or local law enforcement or other investigative agency, a criminal indictment or civil complaint, or probable cause that could support a criminal indictment, or any other credible information in the possession of the Contractor. In this paragraph, "promptly" means to refer information without delay and without change.

49. **EQUAL EMPLOYMENT OPPORTUNITY.** Contractor agrees to, and assures that each of its employees, agents, or subcontractors will, prohibit discrimination based on race, color, religion, sex, sexual orientation, gender identity, or national origin, and: (i) Comply with Title VII of the Civil Rights Act of 1964, as amended, 42 U.S.C. § 2000e, et seq.; (ii) Comply with Title I of the Americans with Disabilities Act of 1990, as amended, 42 U.S.C. §§ 12101, et seq.; (iii) Facilitate compliance with Executive Order No. 11246, "Equal Employment Opportunity" September 24, 1965 (42 U.S.C. § 2000e note), as amended by any later Executive Order that amends or supersedes it in part and is applicable to federal assistance programs; 53 (iv) Comply with federal transit law, specifically 49 U.S.C. § 5332; (v) FTA Circular 4704.1 "Equal Employment Opportunity (EEO) Requirements and Guidelines for Federal Transit Administration Recipients;" and (vi) Follow other federal guidance pertaining to EEO laws, regulations, and requirements. And, if required to do so by U.S. DOT regulations (49 CFR Part 21) or U.S. Department of Labor regulations (41 C.F.R. chapter 60), Contractor agrees to take affirmative action that includes, but is not limited to: (A) Recruitment advertising, recruitment, and employment; (B) Rates of pay and other forms of compensation; (C) Selection for training, including apprenticeship, and upgrading; and (D) Transfers, demotions, layoffs, and terminations. Contractor also recognizes that Title VII of the Civil Rights Act of 1964, as amended, exempts Indian Tribes under the definition of "Employer."

50. **NONDISCRIMINATION.**

- (a) Compliance with Regulations. Contractor shall comply with all applicable laws, rules, and regulations relative to nondiscrimination including, but not limited to the Department of Transportation, Title 49, Code of Federal Regulations, Part 21, and Title 23, Code of Federal Regulations, Part 710.405(b), as they may be amended from time to time (hereinafter referred to as the Regulations), and with Executive Order 11246 titled Equal Employment opportunity, as amended by Executive Order 11375, and as supplemented by Department of Labor Regulation (41 CFR 60) which are herein incorporated by reference and made a part of this contract. Contractor agrees that it will comply with the requirements of U.S. Equal Employment Opportunity Commission, "Regulations to Implement the Equal Employment Provisions of the Americans with Disabilities Act," 29 C.F.R. Part 1630, pertaining to employment of persons with disabilities. In addition, Contractor agrees to comply with any implementing requirements MDOT, FTA, or other governing authority may issue.
- (b) Nondiscrimination. With regard to the work performed by it during this contract, Contractor shall not discriminate on any grounds prohibited by applicable law against any employee or applicant for employment, or in the selection and retention of Subcontractors, including procurement of materials and leases of equipment. Contractor shall not participate either directly or indirectly in discrimination prohibited by Section 21.5 and Part 710.405(b) of the Regulations, including employment practices when the contract covers a program set forth in Appendix B of the Regulations.
- (c) In connection with the performance of services under this contract, Contractor agrees to comply with the State of Michigan provisions for "Prohibition of Discrimination in State Contracts" as set forth in the Elliott-Larsen Civil Rights Act (Public Act 453 of 1976) and the Persons with Disabilities Civil Rights Act (Public Act 220 of 1976) incorporated herein by reference, and as stated in Appendix B. Contractor further covenants that it will comply with the Civil Rights Act of 1964, being P.L. 88-352, 78 Stat. 241, as amended, being Title 42 U.S.C. Sections 1971, 1975a-1975d, and 2000a-2000h-6 and will require similar covenants on the part of any subcontractor employed in the performance of this contract.
- (d) ADA Access. All work performed and all services provided pursuant to this contract shall be in compliance with all policies to ensure that elderly individuals and individuals with disabilities have an equal right to use of public transportation services and facilities. To the extent this Contract requires planning and design of services and facilities, special efforts shall be made to implement the transportation and accessibility rights of elderly individuals and individuals with disabilities. The work performed and services provided in this Contract shall be in compliance with all State and Federal statutes and laws ensuring equal access of transportation services and facilities for the elderly and individuals with disabilities, including, but not limited to, 49 U.S.C. § 5301(d), § 504 of the Rehabilitation Act of 1973, as amended, 29 U.S.C. § 794, The Americans with Disabilities Act of 1990, as amended, 42 U.S.C. § 12101 *et seq.*, and the Architectural Barriers Act of 1968, as amended, 42 U.S.C. § 4151 *et seq.*, and any applicable implementing regulations or directives as they may from time to time be promulgated or amended.
- (e) Contractor assures that neither it nor any of its employees or subcontractors will discriminate on the basis of race, color, national origin, creed, disability, or sex in the performance of this contract. Contractor shall carry out applicable requirements of 49 CFR Part 26 in the award and administration of US DOT-assisted contracts. Failure by the Contractor to carry out these requirements is a material breach of this contract, which may result in the termination of this contract or such other remedy as the recipient deems appropriate.

- (f) In the event of the contractor's noncompliance with the nondiscrimination clauses of this contract or with any of the said rules, regulations, or orders, this contract may be canceled, terminated, or suspended in whole or in part and the contractor may be declared ineligible for further Government contracts or federally assisted construction contracts in accordance with procedures authorized in Executive Order 11246 of September 24, 1965, and such other sanctions may be imposed and remedies invoked as provided in Executive Order 11246 of September 24, 1965, or by rule, regulation, or order of the Secretary of Labor, or as otherwise provided by law.

#### 51. DBE REQUIREMENTS.

- (a) Contractor will carry out the applicable requirements of the Michigan Department of Transportation's and/or the FTA's Disadvantaged Business Enterprise ("DBE") program, Section 11101(3) of the Infrastructure Investment and Jobs Act, all US DOT regulations, 49 CFR 26 including, but not limited to those requirements set forth in Appendix D, attached hereto and made a part hereof, and federal transit law specifically including, but not limited to 49 USC § 5332. Failure by the Contractor to carry out these requirements is a material breach of this Contract, which may result in the termination of this Contract or such other remedy as CATA deems appropriate, which may include, but is not limited to, withholding monthly progress payments, assessing sanctions, liquidated damages and/or disqualifying the Contractor from future bidding as non-responsible.
- (b) Contractor agrees that it and each of its employees, agents, and subcontractors must not discriminate based on race, color, national origin, or sex in the award and performance of any FTA or U.S. DOT-assisted subagreement, third party contract, and third party subcontract, as applicable, and the administration of its DBE program or the requirements of 49 CFR Part 26.
- (c) Contractor agrees to take all necessary and reasonable steps under 49 CFR part 26 to ensure nondiscrimination in the award and administration of US DOT-assisted subagreements, third party contracts, and third party subcontracts as applicable.
- (d) Failure by Contractor to carry out the requirements of this subparagraph is a material breach of the contract, and CATA, MDOT, and or the FTA may impose any of the following remedies, or such other remedy as CATA deems appropriate, including, but are not limited to, withholding monthly progress payments, assessing sanctions, liquidated damages, and/or disqualifying the Contractor from future bidding as non-responsible.
- (e) Consistent with the requirements of 49 CFR 26.29, Contractor shall pay its subcontractors performing work related to this contract for satisfactory performance of that work no later than thirty (30) days after the Contractor's receipt of payment for that work from CATA. In addition, Contractor shall return any retainage payments to those subcontractors within thirty (30) days after the subcontractor's work related to this contract is satisfactorily completed. Contractor must promptly notify CATA whenever a DBE subcontractor performing work related to this contract is terminated or fails to complete the work, and must make good faith efforts to engage another DBE subcontractor to perform at least the same amount of work. The Contractor may not terminate any DBE subcontractor and perform that work through its own forces or those of an affiliate without prior written consent of CATA.

52. CONTINGENT FEES. The Contractor warrants that it has not employed or retained any company or person, other than a bonafide employee working solely for the Contractor, to solicit or secure this contract and that it has not paid or agreed to pay any company or person, other than a bonafide employee working solely for the Contractor, any fee, commission, percentage, brokerage fee, gifts or any other consideration, contingent upon or resulting from the award or making of this contract. For breach or violation of this warranty, CATA shall have the right to annul this contract without liability.

#### 53. ACCESS TO RECORDS/AUDITS.

- (a) The Contractor shall maintain and retain, and shall require all its subcontractors to maintain and retain, complete and accurate books, documents, papers, accounting records, contracts, and other evidence with respect to allowable costs incurred and manpower expended under this contract. All such records shall be maintained on the basis of generally-accepted accounting principles and shall be clearly identified and readily accessible. Contractor's books, documents, and all other records of work performed under the contract and/or at any CATA facility shall be made available during normal business hours to CATA upon request. The Contractor shall also provide during regular business hours to the U.S. Secretary of Transportation, the FTA Administrator, the Comptroller General of the United States, or their duly authorized representatives, and any representatives from MDOT, access to such data and records, and the right to inspect and audit all data and records of the Contractor relating to its performance under the contract, and to make transcripts therefrom as necessary. Unless a longer period is required by law or other provision of these Standard Terms and Conditions, Contractor shall retain all work data, documents, proceedings, and activities related to this contract for a period of three (3) years from the date of final payment under this contract or from expiration or other termination of this contract. In the event of a dispute as to allowable costs or any other issue under this contract, Contractor will thereafter continue to maintain such records until the dispute has been resolved.
- (b) Contractor further agrees to provide: (1) The U.S. Secretary of Transportation and the Comptroller General of the United States, the state, or their duly authorized representatives, access to all contract records as required under 49 U.S.C. § 5325(g); and (2) Sufficient access to all contract records as needed for compliance with applicable federal laws, regulations, and requirements or to assure proper management of the contract as determined by FTA.
- (c) The Contractor certifies that it will comply with the record retention requirements detailed in 2 C.F.R. § 200.333. The Contractor further certifies that it will retain all records as required by 2 C.F.R. § 200.333 for a period of 3 years after termination of the contract.

- (d) To the extent required under federal law, Contractor agrees to provide the following information about federal assistance: 93 (1) The Identification of FTA as the federal agency providing the federal assistance for a State Program or Project; (2) The Catalog of Federal Domestic Assistance Number of the program from which the federal assistance for a State Program or Project is authorized; and (3) The amount of federal assistance FTA has provided for a State Program or Project. (b) Documents. The State agrees to provide the information required under this provision in the following documents: (1) applications for federal assistance, (2) requests for proposals or solicitations, (3) forms, (4) notifications, (5) press releases, and (6) other publications.
54. ACCESS TO THE SITES OF PERFORMANCE. The Contractor agrees to permit FTA and the State of Michigan and its contractors access to the sites of performance under this contract as reasonably may be required.
55. CONFLICT OF INTEREST. The Contractor certifies that, to the best of its knowledge, no CATA employee or office of any public agency interested in this contract has any pecuniary interest in the business of the Contractor and that no person associated with the Contractor has any interest that would conflict in any manner or degree with the performance of this contract. Contractor further covenants that it presently has no interest and shall not acquire any interest, direct or indirect, that would conflict in any manner or degree with the performance of services under the contract. Contractor further covenants in the performance of the contract that no person having any such interest shall be employed by Contractor.
56. INTEREST OF MEMBER OF CONGRESS OR DELEGATES TO CONGRESS. No member of Congress or delegates to the Congress of the United States shall be admitted to any share or part of the contract, or to any benefit arising therefrom. This shall not be construed to prevent any such person from owning stock in a publicly owned corporation.
57. INTEREST OF MEMBERS OF THE STATE LEGISLATURE: No member of the State Legislature shall be admitted to any share or any part of a contract or any benefit arising there from.
58. COMPLIANCE WITH LAWS. The Contractor shall at all times observe and comply with all laws, ordinances, and regulations of the state, federal, local, and city government which may, in any manner, affect the performance of the contract.
59. DEBARMENT AND SUSPENSION. The Contractor shall comply and facilitate compliance with U.S. DOT regulations, "Nonprocurement Suspension and Debarment," 2 C.F.R. part 1200, which adopts and supplements the U.S. Office of Management and Budget (U.S. OMB) "Guidelines to Agencies on Governmentwide Debarment and Suspension (Nonprocurement)," 2 C.F.R. part 180. These provisions apply to each contract at any tier of \$25,000 or more, and to each contract at any tier for a federally required audit (irrespective of the contract amount), and to each contract at any tier that must be approved by an FTA official irrespective of the contract amount. As such, the Contractor shall verify that its principals, affiliates, and subcontractors are eligible to participate in this federally funded contract and are not presently declared by any Federal department or agency to be:
- (a) Debarred from participation in any federally assisted Award;
  - (b) Suspended from participation in any federally assisted Award;
  - (c) Proposed for debarment from participation in any federally assisted Award;
  - (d) Declared ineligible to participate in any federally assisted Award;
  - (e) Voluntarily excluded from participation in any federally assisted Award; or
  - (f) Disqualified from participation in ay federally assisted Award.
- Contractor certifies as follows: The certification in this clause is a material representation of fact relied upon by CATA. If it is later determined by CATA that Contractor knowingly rendered an erroneous certification, in addition to remedies available to the CATA, the Federal Government may pursue available remedies, including but not limited to suspension and/or debarment. The bidder or proposer agrees to comply with the requirements of 2 C.F.R. part 180, subpart C, as supplemented by 2 C.F.R. part 1200. Contractor further agrees to include a provision requiring such compliance in its lower tier covered transactions.
60. FEDERAL CHANGES. Contractor shall at all times comply with all applicable FTA regulations, policies, procedures and directives, including without limitation those listed directly or by reference in the Master Agreement between CATA and FTA, as they may be amended or promulgated from time to time during the term of this contract. Contractor shall not, by action or by inaction, cause CATA to be in violation of FTA regulations, policies, terms, procedures, or directives. Contractor's failure to comply with this paragraph shall constitute a material breach of this contract.
61. STATE CHANGES. Contractor shall at all times comply with all applicable MDOT regulations, policies, procedures and directives, including without limitation those listed directly or by reference in the Master Agreement between CATA and MDOT, as they may be amended or promulgated from time to time during the term of this contract. Contractor shall not, by action or by inaction, cause CATA to be in violation of MDOT regulations, policies, terms, procedures, or directives. Contractor's failure to comply with this paragraph shall constitute a material breach of this contract.
62. GOVERNMENT APPROVAL. If any item required by the contract requires approval for the sale and/or use thereof by statute or regulations, Contractor certifies it has or will obtain an approval for their sale and/or use from the appropriate agency. Contractor will submit to CATA a copy of each such approval for sale and/or use.
63. NO GOVERNMENT OBLIGATION. Notwithstanding any concurrence by the Federal Government or MDOT in, or approval of, the solicitation or award of the contract, absent the express written consent by the Federal Government or by MDOT, neither the Federal Government nor the State of Michigan is a party to the contract, and neither shall be subject to any obligations or liabilities to CATA, the Contractor or any other party (whether or not a party to the contract) pertaining to any matter resulting from the contract. The Contractor

agrees to include this clause in each subcontract financed in whole or in part with Federal assistance provided by FTA. It is further agreed that the clause shall not be modified, except to identify the subcontractor who will be subject to its provisions.

64. ENERGY CONSERVATION. The Contractor agrees to comply with mandatory standards and policies relating to energy efficiency which are contained in the state energy conservation plan issued in compliance with the Energy Policy and Conservation Act.
65. FLY AMERICA REQUIREMENTS. Contractor agrees to comply with 49 U.S.C. 40118 ("Fly America Act") in accordance with the General Services Administration's regulations at 41 CFR Part 301-10, which provide that recipients and subrecipients of federal funds and their contractors are required to use United States Flag air carriers for U.S. Government financed international air travel and transportation of their personal effects or property, to the extent such service is available, unless travel by foreign air carrier is a matter of necessity, as defined by the Fly America Act. The Contractor shall submit, if a foreign air carrier was used, an appropriate certification or memorandum adequately explaining why service by a United States Flag air carrier was not available or why it was necessary to use a foreign air carrier and shall, in any event, provide a certificate of compliance with the Fly America requirements. The Contractor agrees to include the requirements of this section in all subcontracts that may involve international air transportation.
66. FRAUD AND FALSE OR FRAUDULENT STATEMENTS OR RELATED ACTS.
- (a) Civil Fraud. The Contractor acknowledges and agrees that: (i) Federal laws, regulations, and requirements apply to itself and to CATA's Agreement with the FTA, including the Program Fraud Civil Remedies Act of 1986, as amended, 31 U.S.C. § 3801, et seq., and U.S. DOT regulations, "Program Fraud Civil Remedies," 49 CFR Part 31. (ii) Contractor certifies and affirms to CATA and the Federal Government the truthfulness and accuracy of any claim, statement, submission, certification, assurance, affirmation, or representation that the Contractor provides to CATA and/or the Federal Government. (iii) The Federal Government may impose the penalties of the Program Fraud Civil Remedies Act of 1986, as amended, and other applicable penalties if the Contractor presents, submits, or makes available any false, fictitious, or fraudulent information.
  - (b) Criminal Fraud. The Contractor acknowledges that 49 U.S.C. § 5323(l)(1) authorizes the Federal Government to impose the penalties under 18 U.S.C. § 1001 if the Contractor provides a false, fictitious, or fraudulent claim, statement, submission, certification, assurance, or representation in connection with a federal public transportation program under 49 U.S.C. chapter 53 or any other applicable federal law.
  - (c) The Contractor agrees to include the above two clauses in each subcontract financed in whole or in part with Federal assistance by FTA. It is further agreed that the clauses shall not be modified, except to identify the subcontractor who will be subject to the provisions.
67. SAFE OPERATION OF MOTOR VEHICLES
- (a) Seat Belt Use - Contractor is encouraged to adopt and promote on-the-job seat belt use policies and programs for its employees and other personnel that operate company-owned vehicles, company-rented vehicles, or personally operated vehicles. The terms "company-owned" and "company-leased" refer to vehicles owned or leased either by the Contractor or CATA.
  - (b) Distracted Driving - Contractor agrees to adopt and enforce workplace safety policies to decrease crashes caused by distracted drivers, including policies to ban text messaging while using an electronic device supplied by an employer and driving a vehicle the driver owns or rents, a vehicle either Contractor or CATA owns, leases, or rents, or a privately-owned vehicle when on official business in connection with the work performed under the contract.
68. SEISMIC SAFETY. The Contractor agrees that any new building or addition to an existing building will be designed and constructed in accordance with the standards for Seismic Safety required in Department of Transportation Seismic Safety Regulations 49 CFR Part 41 and will certify to compliance to the extent required by the regulation. The Contractor also agrees to ensure that all work performed under this Contract including work performed by a subcontractor is in compliance with the standards required by the Seismic Safety Regulations and the certification of compliance issued on the project.
69. RECOVERED/RECYCLED PRODUCTS AND MATERIALS. The Contractor agrees to comply with all requirements of Section 6002 of the Resource Conservation and Recovery Act ("RCRA"), as amended (42 USC 6962), including but not limited to the regulatory provisions of 40 CFR Part 247, and Executive Order 12873, as they apply to the procurement of the items designated in subpart B of 40 CFR Part 247.
70. FEDERAL WAGE REQUIREMENTS FOR CONSTRUCTION CONTRACTS.
- (a) This procurement is subject to the Davis-Bacon Act, 40 USC § 3141, *et seq*, and to the Copeland Anti-Kickback Act, 18 USC § 874, and to the regulations promulgated thereunder ("the Acts"). As required by federal regulations promulgated under the Acts, the following provisions set forth in Paragraph 13(b) and (c) are incorporated into the Agreement, with the understanding that the term "contracting officer" refers to the appointed representative of CATA.
  - (b) **Davis-Bacon and Copeland Anti-Kickback Acts**
    - (1) **Minimum wages**

All laborers and mechanics employed or working under the site of the work (or under the United States Housing Act of 1937 or under the Housing Act of 1949 in the construction or development of the project), will be paid unconditionally and not less often than once a week, and without subsequent deduction or rebate on any account (except such payroll deductions as are permitted by regulations issued by the Secretary of Labor under the Copeland Act (29 CFR part 3)), the full amount of wages and bona fide fringe benefits (or cash

equivalents thereof) due at time of payment computed at rates not less than those contained in the wage determination of the Secretary of Labor which is attached hereto and made a part hereof, regardless of any contractual relationship which may be alleged to exist between the Contractor and such laborers and mechanics.

Contributions made or costs reasonably anticipated for bona fide fringe benefits under section 1(b)(2) of the Davis-Bacon Act on behalf of laborers or mechanics are considered wages paid to such laborers or mechanics, subject to the provisions of paragraph (1)(iv) of this section; also, regular contributions made or costs incurred for more than a weekly period (but not less often than quarterly) under plans, funds, or programs which cover the particular weekly period, are deemed to be constructively made or incurred during such weekly period. Such laborers and mechanics shall be paid the appropriate wage rate and fringe benefits on the wage determination for the classification of work actually performed, without regard to skill, except as provided in 29 CFR Part 5.5(a)(4). Laborers or mechanics performing work in more than one classification may be compensated at the rate specified for each classification for the time actually worked therein: Provided, That the employer's payroll records accurately set forth the time spent in each classification in which work is performed. The wage determination (including any additional classifications and wage rates conformed under paragraph (1)(ii) of this section) and the Davis-Bacon poster (WH-1321) shall be posted at all times by the Contractor and its subcontractors at the site of the work in a prominent and accessible place where it can be easily seen by the workers.

(A) The contracting officer shall require that any class of laborers or mechanics, including helpers, which is not listed in the wage determination and which is to be employed under the contract shall be classified in conformance with the wage determination. The contracting officer shall approve an additional classification and wage rate and fringe benefits therefore only when the following criteria have been met:

(1) Except with respect to helpers as defined as 29 CFR 5.2(n)(4), the work to be performed by the classification requested is not performed by a classification in the wage determination; and

(2) The classification is utilized in the area by the construction industry; and

(3) The proposed wage rate, including any bona fide fringe benefits, bears a reasonable relationship to the wage rates contained in the wage determination; and

(4) With respect to helpers as defined in 29 CFR 5.2(n)(4), such a classification prevails in the area in which the work is performed.

(B) If the Contractor and the laborers and mechanics to be employed in the classification (if known), or their representatives, and the contracting officer agree on the classification and wage rate (including the amount designated for fringe benefits where appropriate), a report of the action taken shall be sent by the contracting officer to the Administrator of the Wage and Hour Division, Employment Standards Administration, U.S. Department of Labor, Washington, DC 20210. The Administrator, or an authorized representative, will approve, modify, or disapprove every additional classification action within 30 days of receipt and so advise the contracting officer or will notify the contracting officer within the 30-day period that additional time is necessary.

(C) In the event the Contractor, the laborers or mechanics to be employed in the classification or their representatives, and the contracting officer do not agree on the proposed classification and wage rate (including the amount designated for fringe benefits, where appropriate), the contracting officer shall refer the questions, including the views of all interested parties and the recommendation of the contracting officer, to the Administrator for determination. The Administrator, or an authorized representative, will issue a determination within 30 days of receipt and so advise the contracting officer or will notify the contracting officer within the 30-day period that additional time is necessary.

(D) The wage rate (including fringe benefits where appropriate) determined pursuant to paragraphs (a)(1)(ii) (B) or (C) of this section, shall be paid to all workers performing work in the classification under this contract from the first day on which work is performed in the classification.

ii. Whenever the minimum wage rate prescribed in the contract for a class of laborers or mechanics includes a fringe benefit which is not expressed as an hourly rate, the Contractor shall either pay the benefit as stated in the wage determination or shall pay another bona fide fringe benefit or an hourly cash equivalent thereof.

iii. If the Contractor does not make payments to a trustee or other third person, the Contractor may consider as part of the wages of any laborer or mechanic the amount of any costs reasonably anticipated in providing bona fide fringe benefits under a plan or program, Provided, That the Secretary of Labor has found, upon the written request of the Contractor, that the applicable standards of the Davis-Bacon Act have been met. The Secretary of Labor may require the Contractor to set aside in a separate account assets for the meeting of obligations under the plan or program.

iv. (A) The contracting officer shall require that any class of laborers or mechanics which is not listed in the wage determination and which is to be employed under the contract shall be classified in conformance with the wage determination. The contracting officer shall approve an additional classification and wage rate and fringe benefits therefore only when the following criteria have been met:

(1) The work to be performed by the classification requested is not performed by a classification in the wage determination; and

(2) The classification is utilized in the area by the construction industry; and

(3) The proposed wage rate, including any bona fide fringe benefits, bears a reasonable relationship to the wage rates contained in the wage determination.

(B) If the Contractor and the laborers and mechanics to be employed in the classification (if known), or their representatives, and the contracting officer agree on the classification and wage rate (including the amount designated for fringe benefits where appropriate), a report of the action taken shall be sent by the contracting officer to the Administrator of the Wage and Hour Division, Employment Standards Administration, Washington, DC 20210. The Administrator, or an authorized representative, will approve, modify, or disapprove every additional classification action within 30 days of receipt and so advise the contracting officer or will notify the contracting officer within the 30-day period that additional time is necessary.

(C) In the event the Contractor, the laborers or mechanics to be employed in the classification or their representatives, and the contracting officer do not agree on the proposed classification and wage rate (including the amount designated for fringe benefits, where appropriate), the contracting officer shall refer the questions, including the views of all interested parties and the recommendation of the contracting officer, to the Administrator for determination. The Administrator, or an authorized representative, will issue a determination within 30 days of receipt and so advise the contracting officer or will notify the contracting officer within the 30-day period that additional time is necessary.

(D) The wage rate (including fringe benefits where appropriate) determined pursuant to paragraphs (a)(1)(v) (B) or (C) of this section, shall be paid to all workers performing work in the classification under this contract from the first day on which work is performed in the classification.

(2) **Withholding** - Owner shall upon its own action or upon written request of an authorized representative of the Department of Labor withhold or cause to be withheld from the Contractor under this contract or any other Federal contract with the same prime contractor, or any other federally-assisted contract subject to Davis-Bacon prevailing wage requirements, which is held by the same prime contractor, so much of the accrued payments or advances as may be considered necessary to pay laborers and mechanics, including apprentices, trainees, and helpers, employed by the Contractor or any subcontractor the full amount of wages required by the contract. In the event of failure to pay any laborer or mechanic, including any apprentice, trainee, or helper, employed or working on the site of the work (or under the United States Housing Act of 1937 or under the Housing Act of 1949 in the construction or development of the project), all or part of the wages required by the contract, Owner may, after written notice to the Contractor, sponsor, applicant, or agency, take such action as may be necessary to cause the suspension of any further payment, advance, or guarantee of funds until such violations have ceased.

### (3) **Payrolls and basic records**

(i) Payrolls and basic records relating thereto shall be maintained by the Contractor during the course of the work and preserved for a period of three years thereafter for all laborers and mechanics working at the site of the work (or under the United States Housing Act of 1937, or under the Housing Act of 1949, in the construction or development of the project). Such records shall contain the name, address, and social security number of each such worker, his or her correct classification, hourly rates of wages paid (including rates of contributions or costs anticipated for bona fide fringe benefits or cash equivalents thereof of the types described in section 1(b)(2)(B) of the Davis-Bacon Act), daily and weekly number of hours worked, deductions made and actual wages paid. Whenever the Secretary of Labor has found under 29 CFR 5.5(a)(1)(iv) that the wages of any laborer or mechanic include the amount of any costs reasonably anticipated in providing benefits under a plan or program described in section 1(b)(2)(B) of the Davis-Bacon Act, the Contractor shall maintain records which show that the commitment to provide such benefits is enforceable, that the plan or program is financially responsible, and that the plan or program has been communicated in writing to the laborers or mechanics affected, and records which show the costs anticipated or the actual cost incurred in providing such benefits. Contractor's employing apprentices or trainees under approved programs shall maintain written evidence of the registration of apprenticeship programs and certification of trainee programs, the registration of the apprentices and trainees, and the ratios and wage rates prescribed in the applicable programs.

(ii) (A) The Contractor shall submit weekly for each week in which any contract work is performed a copy of all payrolls to Owner for transmission to the Federal Transit Administration. The payrolls submitted shall set out accurately and completely all of the information required to be maintained under section 5.5(a)(3)(i) of Regulations, 29 CFR part 5. This information may be submitted in any form desired. Optional Form WH-347 is available for this purpose and may be purchased from the Superintendent of Documents (Federal Stock Number 029-005-00014-1), U.S. Government Printing Office, Washington, DC 20402. The prime contractor is responsible for the submission of copies of payrolls by all subcontractors.

(B) Each payroll submitted shall be accompanied by a "Statement of Compliance," signed by the Contractor or subcontractor or his or her agent who pays or supervises the payment of the persons employed under the contract and shall certify the following:

(1) That the payroll for the payroll period contains the information required to be maintained under section 5.5(a)(3)(i) of Regulations, 29 CFR part 5 and that such information is correct and complete;

(2) That each laborer or mechanic (including each helper, apprentice, and trainee) employed on the contract during the payroll period has been paid the full weekly wages earned, without rebate, either directly or indirectly, and that no deductions have been made either directly or indirectly from the full wages earned, other than permissible deductions as set forth in Regulations, 29 CFR part 3;

(3) That each laborer or mechanic has been paid not less than the applicable wage rates and fringe benefits or cash equivalents for the classification of work performed, as specified in the applicable wage determination incorporated into the contract.

(C) The weekly submission of a properly executed certification set forth on the reverse side of Optional Form WH-347 shall satisfy the requirement for submission of the "Statement of Compliance" required by paragraph (a)(3)(ii)(B) of this section.

(D) The falsification of any of the above certifications may subject the Contractor or subcontractor to civil or criminal prosecution under section 1001 of title 18 and section 231 of title 31 of the United States Code.

(iii) The Contractor or subcontractor shall make the records required under paragraph (a)(3)(i) of this section available for inspection, copying, or transcription by authorized representatives of the Federal Transit Administration or the Department of Labor, and shall permit such representatives to interview employees during working hours on the job. If the Contractor or subcontractor fails to submit the required records or to make them available, the Federal agency may, after written notice to the Contractor, sponsor, applicant, or agency, take such action as may be necessary to cause the suspension of any further payment, advance, or guarantee of funds. Furthermore, failure to submit the required records upon request or to make such records available may be grounds for debarment action pursuant to 29 CFR 5.12.

#### (4) **Apprentices and trainees**

(i) **Apprentices** - Apprentices will be permitted to work at less than the predetermined rate for the work they performed when they are employed pursuant to and individually registered in a bona fide apprenticeship program registered with the U.S. Department of Labor, Employment and Training Administration, Bureau of Apprenticeship and Training, or with a State Apprenticeship Agency recognized by the Bureau, or if a person is employed in his or her first 90 days of probationary employment as an apprentice in such an apprenticeship program, who is not individually registered in the program, but who has been certified by the Bureau of Apprenticeship and Training or a State Apprenticeship Agency (where appropriate) to be eligible for probationary employment as an apprentice. The allowable ratio of apprentices to journeymen on the job site in any craft classification shall not be greater than the ratio permitted to the Contractor as to the entire work force under the registered program. Any worker listed on a payroll at an apprentice wage rate, who is not registered or otherwise employed as stated above, shall be paid not less than the applicable wage rate on the wage determination for the classification of work actually performed. In addition, any apprentice performing work on the job site in excess of the ratio permitted under the registered program shall be paid not less than the applicable wage rate on the wage determination for the work actually performed. Where a contractor is performing construction on a project in a locality other than that in which its program is registered, the ratios and wage rates (expressed in percentages of the journeyman's hourly rate) specified in the Contractor's or subcontractor's registered program shall be observed. Every apprentice must be paid at not less than the rate specified in the registered program for the apprentice's level of progress, expressed as a percentage of the journeymen hourly rate specified in the applicable wage determination. Apprentices shall be paid fringe benefits in accordance with the provisions of the apprenticeship program. If the apprenticeship program does not specify fringe benefits, apprentices must be paid the full amount of fringe benefits listed on the wage determination for the applicable classification. If the Administrator of the Wage and Hour Division of the U.S. Department of Labor determines that a different practice prevails for the applicable apprentice classification, fringes shall be paid in accordance with that determination. In the event the Bureau of Apprenticeship and Training, or a State Apprenticeship Agency recognized by the Bureau, withdraws approval of an apprenticeship program, the Contractor will no longer be permitted to utilize apprentices at less than the applicable predetermined rate for the work performed until an acceptable program is approved.

(ii) **Trainees** - Except as provided in 29 CFR 5.16, trainees will not be permitted to work at less than the predetermined rate for the work performed unless they are employed pursuant to and individually registered in a program which has received prior approval, evidenced by formal certification by the U.S. Department of Labor, Employment and Training Administration. The ratio of trainees to journeymen on the job site shall not be greater than permitted under the plan approved by the Employment and Training Administration. Every trainee must be paid at not less than the rate specified in the approved program for the trainee's level of progress, expressed as a percentage of the journeyman hourly rate specified in the applicable wage determination. Trainees shall be paid fringe benefits in accordance with the provisions of the trainee program. If the trainee program does not mention fringe benefits, trainees shall be paid the full amount of fringe benefits listed on the wage determination unless the Administrator of the Wage and Hour Division determines that there is an apprenticeship program associated with the corresponding journeyman wage rate on the wage determination which provides for less than full fringe benefits for apprentices. Any employee listed on the payroll at a trainee rate who is not registered and participating in a training plan approved by the Employment and Training Administration shall be paid not less than the applicable wage rate on the wage determination for the classification of work actually performed. In addition, any trainee performing work on the job site in excess of the ratio permitted under the registered program shall be paid not less than the applicable wage rate on the wage determination for the work actually performed. In the event the Employment and Training Administration withdraws approval of a training program, the Contractor will no longer be permitted to utilize trainees at less than the applicable predetermined rate for the work performed until an acceptable program is approved.

(iii) **Equal employment opportunity** - The utilization of apprentices, trainees and journeymen under this part shall be in conformity with the equal employment opportunity requirements of Executive Order 11246, as amended, and 29 CFR part 30.

(5) **Compliance with Copeland Act requirements** - The Contractor shall comply with the requirements of 29 CFR part 3, which are incorporated by reference in this contract.

(6) **Subcontracts** - The Contractor or subcontractor shall insert in any subcontracts the clauses contained in 29 CFR 5.5(a)(1) through (10) and such other clauses as the Federal Transit Administration may by appropriate instructions require, and also a clause requiring the subcontractors to include these clauses in any lower tier subcontracts. The prime contractor shall be responsible for the compliance by any subcontractor or lower tier subcontractor with all the contract clauses in 29 CFR 5.5.

(7) **Contract termination: debarment** - A breach of the contract clauses in 29 CFR 5.5 may be grounds for termination of the contract, and for debarment as a Contractor and a subcontractor as provided in 29 CFR 5.12.

(8) **Compliance with Davis-Bacon and Related Act requirements** - All rulings and interpretations of the Davis-Bacon and Related Acts contained in 29 CFR parts 1, 3, and 5 are herein incorporated by reference in this contract.

(9) **Disputes concerning labor standards** - Disputes arising out of the labor standards provisions of this contract shall not be subject to the general disputes clause of this contract. Such disputes shall be resolved in accordance with the procedures of the Department of Labor set forth in 29 CFR parts 5, 6, and 7. Disputes within the meaning of this clause include disputes between the Contractor (or any of its subcontractors) and the contracting agency, the U.S. Department of Labor, or the employees or their representatives.

(10) **Certification of eligibility**

(i) By entering into this contract, the Contractor certifies that neither it (nor he or she) nor any person or firm who has an interest in the Contractor's firm is a person or firm ineligible to be awarded Government contracts by virtue of section 3(a) of the Davis-Bacon Act or 29 CFR 5.12(a)(1).

(ii) No part of this contract shall be subcontracted to any person or firm ineligible for award of a Government contract by virtue of section 3(a) of the Davis-Bacon Act or 29 CFR 5.12(a)(1).

(iii) The penalty for making false statements is prescribed in the U.S. Criminal Code, 18 U.S.C. 1001.

71. **WORK HOURS.** Contractor agrees to comply with all federal laws, regulations, and requirements providing wage and hour protections for nonconstruction employees.
72. **INSPECTION:** All material shall be received is subject to CATA's right of inspection and rejection, within CATA's sole discretion. Defective material or materials not in accordance with CATA's specifications will be held for Contractor's instructions and at Contractor's expense. Payment for material on an order prior to inspection shall not constitute an acceptance thereof, nor will acceptance remove Contractor's responsibility for latent defects.
73. **PROTESTS.** Any protests shall be filed timely in accordance with the CATA Procurement Protest Procedures. These Procedures are available from the CATA Purchasing & Contracts Manager and the CATA CEO/Executive Director, at the following address: Capital Area Transportation Authority, 4615 Tranter Street, Lansing, MI 48910.
74. **RECOVERED/RECYCLED PRODUCTS AND MATERIALS.** The Contractor agrees to comply with all requirements of Section 6002 of the Resource Conservation and Recovery Act ("RCRA"), as amended (42 USC 6962), including but not limited to the regulatory provisions of 40 CFR Part 247, and Executive Order 12873, as they apply to the procurement of the items designated in subpart B of 40 CFR Part 247.
75. **CARGO PREFERENCE.** The Contractor agrees (a) to use privately owned United States Flag commercial vessels to ship at least 50% of the gross tonnage (computed separately for dry bulk carriers, dry cargo liners, and tankers) involved, whenever shipping any equipment, material, or commodities pursuant to the underlying contract to the extent such vessels are available at fair and reasonable rates for United States Flag commercial vessels; (b) to furnish within twenty (20) working days following the date of loading of shipments originating within the United States or within thirty (30) working days following the date of loading for shipments originating outside the United States, a legible copy of the rated, "on-board" commercial ocean bill of lading, in English, for each shipment of cargo described in the preceding paragraph to the Division of National Cargo, Office of Market Development, Maritime Administration, Washington, D.C., 20590. CATA (through the Contractor in the case of a subcontractor's bill of lading); and (c) to include these requirements in all subcontracts issued pursuant to this contract where the subcontract may involve the transport of equipment, material, or commodities by ocean vessel.
76. **ACTIONS INVOLVING COMMERCE.** Contractor agrees to comply with the Fair Labor Standards Act (FLSA), 29 U.S.C. § 201, et seq. to the extent that the FLSA applies to employees performing work with federal assistance involving commerce, and as the Federal Government otherwise determines applicable.
77. **PATENT RIGHTS.**
- (a) Contractor agrees that: (1) the Federal Government may acquire patent rights when Contractor produces a patented or patentable invention, improvement, or discovery; (2) The Federal Government's rights arise when the patent or patentable information is conceived or reduced to practice with federal assistance provided; or (3) When a patent is issued or patented information becomes available as described in the preceding section 17(a)(2) of the FTA Master Agreement, Contractor will notify CATA so it can make the appropriate disclosures and notifications.
- (b) Contractor agrees that: (1) Its rights and responsibilities in that federally assisted invention, improvement, or discovery will be determined as provided in applicable federal laws, regulations, requirements, and guidance, including any waiver thereof; and (2) Unless the Federal Government determines otherwise in writing, irrespective of its status or the status of any participant as a large business, small business, state government, state instrumentality, local government, Indian tribe, nonprofit organization, institution of higher education, or individual, CATA will transmit the Federal Government's patent rights to FTA, as specified in 35 U.S.C. § 200, et seq., and U.S. Department of Commerce regulations, "Rights to Inventions Made by Nonprofit Organizations and Small Business Firms Under Government Grants, Contracts and Cooperative Agreements," 37 CFR Part 401.
- (c) **License Fees and Royalties.** Consistent with the applicable U.S. DOT Common Rules, Contractor agrees that license fees and royalties for patents, patent applications, and inventions produced with federal assistance are program income, and must be used in compliance with applicable federal requirements.
78. **RIGHTS IN DATA AND COPYRIGHTS.**
- (a) **Definition of "Subject Data."** As used in this section, "subject data" means recorded information, whether or not copyrighted, that is delivered or specified to be delivered as required by the contract. Examples of subject data include, but are not limited to computer

software, standards, specifications, engineering drawings and associated lists, process sheets, manuals, technical reports, catalog item identifications, and related information, but do not include financial reports, cost analyses, or other similar information used for performance or administration of the contract.

(b) The following restrictions apply to all subject data first produced in the performance of the contract:

- (1) Prohibitions. Contractor may not publish or reproduce any subject data, in whole, in part, or in any manner or form, or permit others to do so.
- (2) Exceptions. The prohibitions do not apply to publications or reproductions for the Contractor's own internal use, an institution of higher learning, the portion of subject data that the Federal Government has previously released or approved for release to the public, or the portion of data that has the Federal Government's prior written consent for release.

(c) Contractor agrees that:

- (1) General. It must provide a license to its subject data to the Federal Government that is royalty-free, non-exclusive, and irrevocable. The Federal Government's license must permit the Federal Government to reproduce, publish, or otherwise use the subject data or permit other entities or individuals to use the subject data provided those actions are taken for Federal Government purposes; and
- (2) U.S. DOT Public Access Plan – Copyright License. Contractor grants to U.S. DOT a worldwide, non-exclusive, non-transferable, paid-up, royalty free copyright license, including all rights under copyright, to any and all Publications and Digital Data Sets as such terms are defined in the U.S. DOT Public Access plan, resulting from scientific research funded either fully or partially by this funding agreement. Contractor herein acknowledges that the above copyright license grant is first in time to any and all other grants of a copyright license to such Publications and/or Digital Data Sets, and that U.S. DOT shall have priority over any other claim of exclusive copyright to the same.

79. NO OBLIGATION BY THE FEDERAL GOVERNMENT. Contractor acknowledges and agrees that, notwithstanding any concurrence by the Federal Government in or approval of the solicitation of award of the underlying Contract, absent the express written consent by the Federal Government, the Federal Government is not a party to this Contract and shall not be subject to any obligations or liabilities to CATA, Contractor, or any other party (whether or not a party to that Contract) pertaining to any matter resulting to the underlying Contract. The Contractor agrees to include the above clause in each subcontract financed in whole or in part with Federal assistance provided by the FTA. It is further agreed that the clause shall not be modified, except to identify the subcontractor who will subject to its provisions.

80. PROHIBITION ON CERTAIN TELECOMMUNICATIONS AND VIDEO SURVEILLANCE SERVICES OR EQUIPMENT. Pursuant to the FTA requirements, Contractor understands CATA is prohibited from obligating or expending any loan or grant funds to: 1. Procure or obtain; 2. Extend or renew a contract to procure or obtain; or 3. Enter into a contract (or extend or renew a contract) to procure or obtain equipment, services, Or systems that users covered telecommunications equipment or services as a substantial or essential component of any system, or as critical technology as part of any system. As described in Public Law 115232, section 889, covered telecommunications equipment is telecommunications equipment produced by Huawei Technologies Company or ZTE Corporation (or any subsidiary or affiliate of such entities). For the purpose of public safety, security of government facilities, physical security surveillance of critical infrastructure, and other national security purposes, video surveillance and telecommunications equipment produced by Hytera Communications Corporation, Hangzhou Hikvision Digital Technology Company, or Dahua Technology Company (or any subsidiary or affiliate of such entities). II. Telecommunications or video surveillance services provided by such entities or using such equipment. III. Telecommunications or video surveillance equipment or services produced or provided by an entity that the Secretary of Defense, in consultation with the Director of the National Intelligence or the Director of the Federal Bureau of Investigation, reasonably believes to be an entity owned or controlled by, or otherwise connected to, the government of a covered foreign country

In implementing the prohibition under Public Law 115232, section 889, subsection (f), paragraph(1), heads of executive agencies administering loan, grant, or subsidy programs shall prioritize available funding and technical support to assist affected businesses, institutions and organizations as is reasonably necessary for those affected entities to transition from covered communications equipment and services, to procure replacement equipment and services, and to ensure that communications service to users and customers is sustained. See Public Law 115232, section 889 for additional information.

81. BUILD AMERICA BUY AMERICA PROVISIONS. Construction materials used in the Project are subject to the domestic preference requirement of the Build America, Buy America Act, Pub. L. 117-58, div. G, tit. IX, §§ 70911 – 70927 (2021), as implemented from time to time by the U.S. Office of Management and Budget, the U.S. Department of Transportation, and FTA. The VENDOR acknowledges that this agreement is neither a waiver of § 70914(a) nor a finding under § 70914(b).

82. NATIONAL INTELLIGENT TRANSPORTATION SYSTEMS ARCHITECTURE AND STANDARDS. Contactor agrees to conform to the National Intelligent Transportation Systems (ITS) Architecture requirements of 23 U.S.C. § 517(d), unless it obtains an exemption from those requirements, and to follow FTA Notice, "FTA National ITS Architecture Policy on Transit Projects," 66 Fed. Reg. 1455, January 8, 2001, and all other applicable federal guidance.

**APPENDIX B****PROHIBITION OF DISCRIMINATION IN STATE CONTRACTS**

In connection with the performance of work under this contract, Contractor agrees as follows:

1. In accordance with Act 453, Public Acts of 1976, Contractor hereby agrees not to discriminate against an employee or applicant for employment with respect to hire, tenure, terms, conditions, or privileges of employment, or as a matter directly or indirectly related to employment, because of race, color, religion, national origin, age, sex, height, weight, or marital status. Further, in accordance with Act No. 220, Public Acts of 1976 as amended by Act No. 478, Public Acts of 1980, Contractor hereby agrees not to discriminate against an employee or applicant for employment with respect to hire, tenure, terms, conditions, or privileges of employment, or a matter directly or indirectly related to employment, because of a disability that is unrelated to the individual's ability to perform the duties of a particular job or position. A breach of the above covenants shall be regarded as a material breach of this contract.
2. Contractor hereby agrees that any and all subcontracts to this contract, whereby a portion of the work set forth in this contract is to be performed, shall contain a covenant the same as hereinabove set forth in Section 1 of this Appendix.
3. Contractor will take affirmative action to insure that applicants for employment and employees are treated without regard to their race, color, religion, national origin, age, sex, height, weight, marital status or a disability that is unrelated to the individual's ability to perform the duties of a particular job or position. Such action shall include, but not be limited to the following: employment, upgrading, demotion or transfer, recruitment advertising; layoff or termination; rates of pay or other forms of compensation; and selection for training, including apprenticeship.
4. Contractor will, in all solicitations or advertisements for employees placed by or on behalf of Contractor, state that all qualified applicants will receive consideration for employment without regard to race, color, religion, national origin, age, sex, height, weight, marital status or disability that is unrelated to the individual's ability to perform the duties of a particular job or position.
5. Contractor or its collective bargaining representative will send to each labor union or representative of workers with which it has a collective bargaining agreement or other contract or understanding, a notice advising the said labor union or workers' representative of the Contractor's commitments under this appendix.
6. Contractor will comply with all relevant published rules, regulations, directives, and orders of the Michigan Civil Rights Commission which may be in effect prior to the taking of bids for any individual state project.
7. Contractor will furnish and file compliance reports within such time and upon such forms as provided by the Michigan Civil Rights Commission, said forms may also elicit information as to the practices, policies, program, and employment statistics of each subcontractor as well as Contractor itself, and said Contractor will permit access to its books, records, and accounts by the Michigan Civil Rights Commission and/or its agent, for purposes of investigation to ascertain compliance with this contract and relevant with rules, regulations, and orders of the Michigan Civil Rights Commission.
8. In the event that the Civil Rights Commission finds, after a hearing held pursuant to its rules, that Contractor has not complied with the contractual obligations under this Agreement, the Civil Rights Commission may, as part of its order based upon such findings, certify said findings to the Administrative Board of the State of Michigan, which Administrative Board may order the cancellation of the contract found to have been violated and/or declare Contractor ineligible for future contracts with the state and its political and civil subdivisions, departments, and officers, and including the governing boards of institutions of higher education, until Contractor complies with said order of the Civil Rights Commission. Notice of said declaration of future ineligibility may be given to any or all of the persons with whom Contractor is declared ineligible to contract as a contracting party in future contracts. In any case before the Civil Rights Commission in which cancellation of an existing contract is a possibility, the contracting agency shall be notified of such possible remedy and shall be given the option by the Civil Rights Commission to participate in such proceedings.
9. Contractor will include, or incorporate by reference, the provisions of the foregoing paragraphs (1) through (8) in every subcontract or purchase order unless exempted by the rules, regulations or orders of the Michigan Civil Rights Commission, and will provide in every subcontract or purchase order that said provisions will be binding upon each subcontractor or seller.

The contractor will take such action with respect to any subcontract or purchase order as the administering agency may direct as a means of enforcing such provisions,

*Provided*, however, that in the event a contractor becomes involved in, or is threatened with, litigation with a subcontractor or vendor as a result of such direction by the administering agency, the contractor may request the United States to enter into such litigation to protect the interests of the United States.

The applicant further agrees that it will be bound by the above equal opportunity clause with respect to its own employment practices when it participates in federally assisted construction work: *Provided*, That if the applicant so participating is a State or local government, the above equal opportunity clause is not applicable to any agency, instrumentality or subdivision of such government which does not participate in work on or under the contract.

The applicant agrees that it will assist and cooperate actively with the administering agency and the Secretary of Labor in obtaining the compliance of contractors and subcontractors with the equal opportunity clause and the rules, regulations, and relevant orders of the Secretary of Labor, that it will furnish the administering agency and the Secretary of Labor such information as they may require for the supervision of such compliance, and that it will otherwise assist the administering agency in the discharge of the agency's primary responsibility for securing compliance.

The applicant further agrees that it will refrain from entering into any contract or contract modification subject to Executive Order 11246 of September 24, 1965, with a contractor debarred from, or who has not demonstrated eligibility for, Government contracts and federally assisted construction contracts pursuant to the Executive Order and will carry out such sanctions and penalties for violation of the equal opportunity clause as may be imposed upon contractors and subcontractors by the administering agency or the Secretary of Labor pursuant to Part II, Subpart D of the Executive Order. In addition, the applicant agrees that if it fails or refuses to comply with these undertakings, the administering agency may take any or all of the following actions: Cancel, terminate, or suspend in whole or in part this grant (contract, loan, insurance, guarantee); refrain from extending any further assistance to the applicant under the program with respect to which the failure or refund occurred until satisfactory assurance of future compliance has been received from such applicant; and refer the case to the Department of Justice for appropriate legal proceedings. including sanctions for noncompliance.

**APPENDIX C****ASSURANCES THAT CONTRACTORS AND SUBCONTRACTORS MUST MAKE PURSUANT TO US DOT  
REGULATION 49 CFR § 26, et seq**

- A. Contractor, subrecipient or subcontractor shall not discriminate on the basis of race, color, national origin, or sex, in the performance of this contract. Contractor shall carry out applicable requirements of 49 CFR § 26 in the award and administration of DOT-assisted contracts. Failure of the Contractor to carry out these requirements is a material breach of this contract, which may result in the termination of this contract or such other remedy as the recipient deems appropriate, which may include, but is not limited to:
1. Withholding monthly progress payments;
  2. Assessing sanctions;
  3. Liquidated damages; and/or
  4. Disqualifying the Contractor from further bidding as non-responsible.
- B. Each contract Contractor signs with a subcontractor must include the preceding assurance.

**APPENDIX D****CATA Board Policy No. 204****DISADVANTAGED BUSINESS ENTERPRISE POLICY**

The Capital Area Transportation Authority (CATA) has established a Disadvantaged Business Enterprise (DBE) program in accordance with regulations of the U.S. Department of Transportation (DOT), 49 CFR Part 26. CATA has received Federal financial assistance from the Department of Transportation, and as a condition of receiving this assistance, CATA has signed an assurance that it will comply with 49 CFR Part 26.

It is the policy of CATA to ensure that DBEs are defined in part 26, have an equal opportunity to receive and participate in DOT-assisted contracts. It is also our policy:

1. To ensure nondiscrimination in the award and administration of DOT - assisted contracts;
2. To create a level playing field on which DBEs can compete fairly for DOT - assisted contracts;
3. To ensure that the DBE Program is narrowly tailored in accordance with applicable law;
4. To ensure that only firms that fully meet 49 CFR Part 26 eligibility standards are permitted to participate as DBEs;
5. To help remove barriers to the participation of DBEs in DOT-assisted contracts;
6. To assist the development of firms that can compete successfully in the market place outside the DBE Program.

The Purchasing and Contracts Manager has been delegated as the DBE Liaison Officer. In that capacity, the Purchasing and Contracts Manager is responsible for implementing all aspects of the DBE program. Implementation of the DBE program is accorded the same priority as compliance with all other legal obligations incurred by CATA in its financial assistance agreements with the Department of Transportation.

CATA has disseminated this policy statement to the Board of Directors and all of the components of our organization. We have distributed this statement to DBE and non-DBE business communities that perform work for us on DOT-assisted contracts. CATA will give public notice of DBE goals, how the goals were determined, and contact information for public comment.

Adopted: 04/20/2022

### EXHIBIT J WAGE DETERMINATION

"General Decision Number: MI20250001 01/03/2025

Superseded General Decision Number: MI20240001

State: Michigan

Construction Types: Highway (Highway, Airport & Bridge xxxxx and Sewer/Incid. to Hwy.)

Counties: Michigan Statewide.

Note: Contracts subject to the Davis-Bacon Act are generally required to pay at least the applicable minimum wage rate required under Executive Order 14026 or Executive Order 13658.

Please note that these Executive Orders apply to covered contracts entered into by the federal government that are subject to the Davis-Bacon Act itself, but do not apply to contracts subject only to the Davis-Bacon Related Acts, including those set forth at 29 CFR 5.1(a)(1).

If the contract is entered into on or after January 30, 2022, or the contract is renewed or extended (e.g., an option is exercised) on or after January 30, 2022:	Executive Order 14026 generally applies to the contract. The contractor must pay all covered workers at least \$17.75 per hour (or the applicable wage rate listed on this wage determination, if it is higher) for all hours spent performing on the contract in 2025.
---	---

If the contract was awarded on or between January 1, 2015 and January 29, 2022, and the contract is not renewed or extended on or after January 30, 2022:	Executive Order 13658 generally applies to the contract. The contractor must pay all covered workers at least \$13.30 per hour (or the applicable wage rate listed on this wage determination, if it is higher) for all hours spent performing on that contract in 2025.
---	--

The applicable Executive Order minimum wage rate will be adjusted annually. If this contract is covered by one of the Executive Orders and a classification considered necessary for performance of work on the contract does not appear on this wage determination, the contractor must still submit a conformance request.

Additional information on contractor requirements and worker protections under the Executive Orders is available at <http://www.dol.gov/whd/govcontracts>.

Modification Number	Publication Date
0	01/03/2025

CARP0004-004 06/01/2019

REMAINDER OF STATE

Rates	Fringes
-------	---------

CARPENTER ( Piledriver).....\$ 27.62      20.59

-----  
 CARP0004-005 06/01/2018

LIVINGSTON (Townships of Brighton, Deerfield, Genoa, Hartland, Oceola & Tyrone), MACOMB, MONROE, OAKLAND, SANILAC, ST. CLAIR AND WAYNE COUNTIES

Rates      Fringes

CARPENTER (Piledriver).....\$ 30.50      27.28

-----  
 ELEC0017-005 06/01/2024

STATEWIDE

Rates      Fringes

Line Construction

Groundman/Driver.....\$ 32.00      33%+7.31  
 Journeyman Signal Tech,  
 Communications Tech, Tower  
 Tech & Fiber Optic Splicers.\$ 47.35      33%+7.31  
 Journeyman Specialist.....\$ 54.45      33%+7.31  
 Operator A.....\$ 40.09      33%+7.31  
 Operator B.....\$ 37.46      33%+7.31

Classifications

Journeyman Specialist: Refers to a crew of only one person working alone.  
 Operator A: Shall be proficient in operating all power equipment including: Backhoe, Excavator, Directional Bore and Boom/Digger truck.  
 Operator B: Shall be proficient in operating any 2 of the above mentioned pieces of equipment listed under Operator A.

-----  
 ENGI0324-003 06/01/2024

ALCONA, ALPENA, ARENAC, BAY, CHEBOYGAN, CLARE, CLINTON, CRAWFORD, GENESEE, GLADWIN, GRATIOT, HURON, INGHAM, IOSCO, ISABELLA, JACKSON, LAPEER, LENAWEE, LIVINGSTON, MACOMB, MIDLAND, MONROE, MONTMORENCY, OAKLAND, OGEMAW, OSCODA, OTSEGO, PRESQUE ISLE, ROSCOMMON, SAGINAW, ST. CLAIR, SANILAC, SHIAWASSEE, TUSCOLA, WASHTENAW AND WAYNE COUNTIES:

Rates      Fringes

OPERATOR: Power Equipment  
 (Steel Erection)

GROUP 1.....\$ 55.42      25.25  
 GROUP 2.....\$ 56.42      25.25  
 GROUP 3.....\$ 53.92      25.25  
 GROUP 4.....\$ 54.92      25.25  
 GROUP 5.....\$ 52.42      25.25  
 GROUP 6.....\$ 53.42      25.25  
 GROUP 7.....\$ 52.15      25.25  
 GROUP 8.....\$ 53.15      25.25  
 GROUP 9.....\$ 51.70      25.25  
 GROUP 10.....\$ 52.70      25.25  
 GROUP 11.....\$ 50.97      25.25  
 GROUP 12.....\$ 51.97      25.25  
 GROUP 13.....\$ 50.61      25.25  
 GROUP 14.....\$ 51.61      25.25  
 GROUP 15.....\$ 49.97      25.25  
 GROUP 16.....\$ 46.77      25.25  
 GROUP 17.....\$ 32.29      12.40  
 GROUP 18.....\$ 35.78      25.25

FOOTNOTE:

Paid Holidays: New Year's Day, Memorial Day, Fourth of July, Labor Day, Thanksgiving Day and Christmas Day.

POWER EQUIPMENT OPERATOR CLASSIFICATIONS

- GROUP 1: Engineer when operating combination of boom and jib 400' or longer
- GROUP 2: Engineer when operating combination of boom and jib 400' or longer on a crane that requires an oiler
- GROUP 3: Engineer when operating combination of boom and jib 300' or longer
- GROUP 4: Engineer when operating combination of boom and jib 300' or longer on a crane that requires an oiler
- GROUP 5: Engineer when operating combination of boom and jib 220' or longer
- GROUP 6: Engineer when operating combination of boom and jib 220' or longer on a crane that requires an oiler
- GROUP 7: Engineer when operating combination of boom and jib 140' or longer
- GROUP 8: Engineer when operating combination of boom and jib 140' or longer on a crane that requires an oiler
- GROUP 9: Tower crane & derrick operator (where operator's work station is 50 ft. or more above first sub-level)
- GROUP 10: Tower crane & derrick operator (where operator's work station is 50 ft. or more above first sub-level) on a crane that requires an oiler
- GROUP 11: Engineer when operating combination of boom and jib 120' or longer
- GROUP 12: Engineer when operating combination of boom and jib 120' or longer on a crane that requires an oiler
- GROUP 13: Crane operator; job mechanic and 3 drum hoist and excavator
- GROUP 14: Crane operator on a crane that requires an oiler
- GROUP 15: Hoisting operator; 2 drum hoist and rubber tired backhoe
- GROUP 16: Forklift and 1 drum hoist
- GROUP 17: Compressor or welder operator
- GROUP 18: Oiler

-----  
 ENGI0324-004 06/01/2024

AREA 1: ALLEGAN, BARRY, BERRIEN, BRANCH, CALHOUN, CASS, EATON, HILLSDALE, IONIA, KALAMAZOO, KENT, LAKE, MANISTEE, MASON, MECOSTA, MONTCALM, MUSKEGON, NEWAYGO, OCEANA, OSCEOLA, OTTAWA, ST. JOSEPH, VAN BUREN

AREA 2: ANTRIM, BENZIE, CHARLEVOIX, EMMET, GRAND TRAVERSE, KALKASKA, LEELANAU, MISSAUKEE AND WEXFORD COUNTIES:

Rates Fringes

OPERATOR: Power Equipment  
 (Steel Erection)

AREA 1		
GROUP 1.....	\$ 55.02	25.25
GROUP 2.....	\$ 52.15	25.25
GROUP 3.....	\$ 50.61	25.25
GROUP 4.....	\$ 46.77	25.25
GROUP 5.....	\$ 32.29	12.40
GROUP 6.....	\$ 35.78	25.25
AREA 2		

GROUP 1.....	\$ 55.02	25.25
GROUP 2.....	\$ 52.15	24.25
GROUP 3.....	\$ 50.61	25.25
GROUP 4.....	\$ 46.77	25.25
GROUP 5.....	\$ 32.29	12.40
GROUP 6.....	\$ 35.78	25.25

FOOTNOTES:

Crane operator with main boom and jib 300' or longer: \$1.50 additional to the group 1 rate. Crane operator with main boom and jib 400' or longer: \$3.00 additional to the group 1 rate.

PAID HOLIDAYS: New Year's Day, Memorial Day, Fourth of July, Labor Day, Thanksgiving Day and Christmas Day.

POWER EQUIPMENT OPERATOR CLASSIFICATIONS:

GROUP 1: Crane Operator with main boom & jib 400', 300', or 220' or longer.

GROUP 2: Crane Operator with main boom & jib 140' or longer, Tower Crane; Gantry Crane; Whirley Derrick.

GROUP 3: Regular Equipment Operator, Crane, Dozer, Loader, Hoist, Straddle Wagon, Mechanic, Grader and Hydro Excavator.

GROUP 4: Air Tugger (single drum), Material Hoist Pump 6" or over, Elevators, Brokk Concrete Breaker.

GROUP 5: Air Compressor, Welder, Generators, Conveyors

GROUP 6: Oiler and fire tender

-----  
ENGI0324-005 09/01/2024

AREA 1: GENESEE, LAPEER, LIVINGSTON, MACOMB, MONROE, OAKLAND, ST. CLAIR, WASHTENAW AND WAYNE COUNTIES

AREA 2: ALCONA, ALLEGAN, ALGER, ALPENA, ANTRIM, ARENAC, BARAGA, BARRY, BAY, BENZIE, BERRIEN, BRANCH, CALHOUN, CASS, CHARLEVOIX, CHEBOYGAN, CHIPPEWA, CLARE, CLINTON, CRAWFORD, DELTA, DICKINSON, EATON, EMMET, GLADWIN, GOGEBIC, GRAND TRAVERSE, GRATIOT, HILLSDALE, HOUGHTON, HURON, INGHAM, IONIA, IOSCO, IRON, ISABELLA, JACKSON, KALAMAZOO, KALKASKA, KENT, KWEENAW, LAKE, LEELANAU, LENAWEE, LUCE, MACKINAC, MANISTEE, MARQUETTE, MASON, MECOSTA, MENOMINEE, MIDLAND, MISSAUKEE, MONTCALM, MONTMORENCY, MUSKEGON, NEWAYGO, OCEANA, OGEMAW, ONTONAGON, OSCEOLA, OSCODA, OTSEGO, OTTAWA, PRESQUE ISLE, ROSCOMMON, SAGINAW, SANILAC, SCHOOLCRAFT, SHIAWASSEE, ST. JOSEPH, TUSCOLA, VAN BUREN AND WEXFORD COUNTIES

Rates      Fringes

OPERATOR: Power Equipment  
(Underground construction  
(including sewer))

AREA 1:

GROUP 1.....	\$ 43.48	25.25
GROUP 2.....	\$ 38.75	25.25
GROUP 3.....	\$ 38.02	25.25
GROUP 4.....	\$ 37.45	25.25
GROUP 5.....	\$ 27.85	12.10

AREA 2:

GROUP 1.....	\$ 43.48	25.25
GROUP 2.....	\$ 38.75	25.25
GROUP 3.....	\$ 38.02	25.25
GROUP 4.....	\$ 37.45	25.25
GROUP 5.....	\$ 27.85	12.10

POWER EQUIPMENT OPERATOR CLASSIFICATIONS

GROUP 1: Backfiller tamper; Backhoe; Batch plant operator (concrete); Clamshell; Concrete paver (2 drums or larger); Conveyor loader (Euclid type); Crane (crawler, truck type)

or pile driving); Dozer; Dragline; Elevating grader; Endloader; Gradall (and similar type machine); Grader; Mechanic; Power shovel; Roller (asphalt); Scraper (self-propelled or tractor drawn); Side boom tractor (type D-4 or equivalent and larger); Slip form paver; Slope paver; Trencher (over 8 ft. digging capacity); Well drilling rig; Concrete pump with boom operator; Hydro Excavator

GROUP 2: Boom truck (power swing type boom); Crusher; Hoist; Pump (1 or more - 6-in. discharge or larger - gas or diesel- powered or powered by generator of 300 amperes or more - inclusive of generator); Side boom tractor (smaller than type D-4 or equivalent); Tractor (pneu-tired, other than backhoe or front end loader); Trencher (8-ft. digging capacity and smaller); Vac Truck and End dump operator;

GROUP 3: Air compressors (600 cfm or larger); Air compressors (2 or more-less than 600 cfm); Boom truck (non-swinging, non- powered type boom); Concrete breaker (self-propelled or truck mounted - includes compressor); Concrete paver (1 drum-1/2 yd. or larger); Elevator (other than passenger); Maintenance person; Pump (2 or more-4-in. up to 6-in. discharge-gas or diesel powered - excluding submersible pumps); Pumpcrete machine (and similar equipment); Wagon drill (multiple); Welding machine or generator (2 or more-300 amp. or larger - gas or diesel powered)

GROUP 4: Boiler; Concrete saw (40 hp or over); Curing machine (self-propelled); Farm tractor (with attachment); Finishing machine (concrete); Hydraulic pipe pushing machine; Mulching equipment; Pumps (2 or more up to 4-in. discharge, if used 3 hours or more a day, gas or diesel powered - excluding submersible pumps); Roller (other than asphalt); Stump remover; Trencher (service); Vibrating compaction equipment, self-propelled (6 ft. wide or over); Sweeper (Wayne type); Water wagon and Extend-a boom forklift

Group 5: Fire Person, Oiler

-----  
ENGI0324-006 06/01/2024

GENESEE, MACOMB, MONROE, OAKLAND, WASHTENAW, WAYNE, ALCONA, ALGER, ALLEGAN, ALPENA, ANTRIM, ARENAC, BARAGA, BARRY, BAY, BENZIE, BERRIEN, BRANCH, CALHOUN, CASS, CHARLEVOIX, CHEBOYGAN, CHIPPEWA, CLARE, CLINTON, CRAWFORD, DELTA, DICKINSON, EATON, EMMET, GLADWIN, GOGEBIC, GRAND TRAVERSE, GRATIOT, HILLSDALE, HOUGHTON, HURON, INGHAM, IONIA, IOSCO, IRON, ISABELLA, JACKSON, KALAMAZOO, KALKASKA, KENT, KEWEENAW, LAKE, LAPEER, LEELANAU, LENAWEE, LIVINGSTON, LUCE, MACKINAC, MANISTEE, MARQUETTE, MASON, MECOSTA, MENOMINEE, MIDLAND, MISSAUKEE, MONTCALM, MONTMORENCY, MUSKEGON, NEWAYGO, OCEANA, OGEMAW, ONTONAGON, OSCEOLA, OSCODA, OTSEGO, OTTAWA, PRESQUE ISLE, ROSCOMMON, SAGINAW, ST. CLARE, ST. JOSEPH, SANILAC, SCHOOLCRAFT, SHIAWASSEE, TUSCOLA, VAN BUREN AND WEXFORD COUNTIES

Rates Fringes

Power equipment operators:

(AIRPORT, BRIDGE & HIGHWAY CONSTRUCTION)

GROUP 1.....	\$ 43.71	25.25
GROUP 2.....	\$ 42.56	25.25
GROUP 3.....	\$ 35.83	25.25
GROUP 4.....	\$ 35.27	25.25

POWER EQUIPMENT OPERATOR CLASSIFICATIONS

GROUP 1: Paver Operator (5 bags or more); Slip Form Paver; Asphalt Paver (self propelled); Shovel (Excavator) installing utilities over 20 feet in depth.

Group 2: Asphalt plant operator; crane operator (does not include work on bridge construction projects when the crane operator is erecting structural components); Dragline operator; Shovel (Excavator) operator; Locomotive operator; Elevating grader operator; Pile driving operator; Roller operator (asphalt); Blade grader operator; Trenching machine operator (ladder or wheel type); Auto-grader; Self-propelled or tractor-drawn scraper; Conveyor loader operator (Euclid type); Bulldozer; Hoisting engineer; Tractor operator; Finishing machine operator (asphalt); Mechanic; Pump operator (6-in. discharge or over, gas, diesel powered or generator of 300 amp. or larger); Shouldering or gravel distributing machine operator (self-propelled); Backhoe (with over 3/8 yd. bucket); Side boom tractor (type D-4 or equivalent or larger); Tube finisher (slip form paving); Gradall (and similar type machine); Asphalt planner (self- propelled); Batch plant (concrete-central mix); Slurry machine (asphalt); Concrete pump (3 in. and over); Roto-mill; Swinging boom truck (over 12 ton capacity); Hydro demolisher (water blaster); Farm-type tractor with attached pan; Vacuum truck operator; Batch Plant (concrete dry batch); Concrete Saw Operator (40h.p. or over; Tractor Operator (farm type); Finishing Machine Operator (concrete); Grader Operator (self-propelled fine grade or form (concrete); tractor operator (farm type with attachment); Wagon Drill operator; Boom or winch hoist truck operator.

GROUP 3: Screening plant operator; Washing plant operator; Crusher operator; Backhoe (with 3/8 yd. bucket or less); Side boom tractor (smaller than D-4 type or equivalent); Sweeper (Wayne type and similar equipment); Greese Truck; Air Compressor Operator (600 cu.ft. per min or more); Air Compressor Operator (two or more, less than 600 cfm); End Loader operator (1 yard Capacity and over); Side boom tractor (type D or equivalent or larger; Endloader operator \*under 1 yard capacity; Trencher (service).

GROUP 4: Boiler fire tender; Concrete Breaker; Oiler; Fire tender; Trencher (service); Flexplane operator; Cleftplane operator; Roller operator (other than asphalt); Curing equipment operator (self-propelled); Power bin operator; Plant drier operator (asphalt); Vibratory compaction equipment operator (6 ft. wide or over); Guard post driver operator (power driven); All mulching equipment; Stump remover; Concrete pump (under 3-in.); Mesh installer (self-propelled); End dump; Skid steer.

-----  
ENGI0324-007 05/01/2024

ALGER, BARAGA, CHIPPEWA, DELTA, DICKINSON, GOGEBIC, HOUGHTON, IRON, KEWEENAW, LUCE, MACKINAC MARQUETTE, MENOMINEE, ONTONAGON AND SCHOOLCRAFT COUNTIES:

	Rates	Fringes
OPERATOR: Power Equipment (Steel Erection)		
Compressor, welder and forklift.....	\$ 40.90	25.00
Crane operator, main boom & jib 120' or longer.....	\$ 47.37	25.00
Crane operator, main boom & jib 140' or longer.....	\$ 47.37	24.60
Crane operator, main boom & jib 220' or longer.....	\$ 48.26	25.00
Mechanic with truck and tools.....	\$ 46.50	25.00
Oiler and fireman.....	\$ 39.96	25.00
Regular operator.....	\$ 44.72	25.00

-----  
ENGI0324-008 10/01/2023

ALCONA, ALGER, ALLEGAN, ALPENA, ANTRIM, ARENAC, BARAGA, BARRY, BAY, BENZIE, BERRIEN, BRANCH, CALHOUN, CASS, CHARLEVOIX, CHEBOYGAN, CHIPPEWA, CLARE, CLINTON, CRAWFORD, DELTA, DICKINSON, EATON, EMMET, GENESEE, GLADWIN, GOGEBIC, GRAND TRAVERSE, GRATIOT, HILLSDALE, HOUGHTON, HURON, INGHAM, IONIA, IOSCO, IRON, ISABELLA, JACKSON, KALAMAZOO, KALKASKA, KENT, KEWEENAW, LAKE, LAPEER, LEELANAU, LENAWEE, LIVINGSTON, LUCE, MACKINAC, MACOMB, MANISTEE, MARQUETTE, MASON, MECOSTA, MENOMINEE, MIDLAND, MISSAUKEE, MONTCALM, MONTMORENCY, MONROE, MUSKEGON, NEWAYGO, OAKLAND, OCEANA, OGEMAW, ONTONAGON, OSCEOLA, OSCODA, OTSEGO, OTTAWA, PRESQUE ISLE, ROSCOMMON, SAGINAW, ST. CLARE, ST. JOSEPH, SANILAC, SCHOOLCRAFT, SHIAWASSEE, TUSCOLA, VAN BUREN, WASHTENAW, WAYNE AND WEXFORD COUNTIES

	Rates	Fringes
OPERATOR: Power Equipment (Sewer Relining)		
GROUP 1.....	\$ 37.37	15.44
GROUP 2.....	\$ 35.33	15.44

SEWER RELINING CLASSIFICATIONS

GROUP 1: Operation of audio-visual closed circuit TV system, including remote in-ground cutter and other equipment used in connection with the CCTV system

GROUP 2: Operation of hot water heaters and circulation systems, water jettors and vacuum and mechanical debris removal systems

-----  
ENGI0325-012 05/01/2024

Rates Fringes

Power equipment operators -  
gas distribution and duct  
installation work:

GROUP 1.....	\$ 37.98	25.25
GROUP 2.....	\$ 34.75	25.25

SCOPE OF WORK: The construction, installation, treating and reconditioning of pipelines transporting gas vapors within cities, towns, subdivisions, suburban areas, or within private property boundaries, up to and including private meter settings of private industrial, governmental or other premises, more commonly referred to as "distribution work," starting from the first metering station, connection, similar or related facility, of the main or cross country pipeline and including duct installation.

Group 1: Backhoe, crane, grader, mechanic, dozer (D-6 equivalent or larger), side boom (D-4 equivalent or larger), trencher(except service), endloader (2 yd. capacity or greater).

GROUP 2: Dozer (less than D-6 equivalent), endloader (under 2 yd. capacity), side boom (under D-4 capacity), backfiller, pumps (1 or 2 of 6-inch discharge or greater), boom truck (with powered boom), tractor (wheel type other than backhoe or front endloader). Tamper (self-propelled), boom truck (with non-powered boom), concrete saw (20 hp or larger), pumps (2 to 4 under 6-inch discharge), compressor (2 or more or when one is used continuously into the second day) and trencher(service). Oiler, hydraulic pipe pushing machine, grease person and hydrostatic testing operator.

-----  
IRON0008-007 06/01/2024

ALGER, BARAGA, CHIPPEWA, DELTA, DICKINSON, GOGEBIC, HOUGHTON, IRON, KEWEENAW, LUCE, MACKINAC MARQUETTE, MENOMINEE, ONTONAGON AND SCHOOLCRAFT COUNTIES:

Rates Fringes

Ironworker - pre-engineered  
metal building erector.....\$ 23.70 6.95

IRONWORKER

General contracts \$10,000,000 or greater.....	\$ 39.91	32.32
General contracts less than \$10,000,000.....	\$ 39.91	32.32

Paid Holidays: New Year's Day, Memorial Day, July 4th, Labor Day, Thanksgiving Day & Christmas Day.

-----  
IRON0025-002 06/01/2024

ALCONA, ALPENA, ARENAC, BAY, CHEBOYGAN, CLARE, CLINTON, CRAWFORD, GENESEE, GLADWIN, GRATIOT, HURON, INGHAM, IOSCO, ISABELLA, JACKSON, LAPEER, LIVINGSTON, MACOMB, MIDLAND, MONTMORENCY, OAKLAND, OGEMAW, OSCODA, OTSEGO, PRESQUE ISLE, ROSCOMMON, SAGINAW, SANILAC, SHIAWASSEE, ST. CLAIR, TUSCOLA, WASHTENAW AND WAYNE COUNTIES:

Rates Fringes

Ironworker - pre-engineered  
metal building erector

ALLEGAN, ANTRIM, BARRY, BENZIE, BRANCH, CALHOUN, CHARLEVOIX, EATON, EMMET, GRAND TRAVERSE, HILLSDALE, IONIA, KALAMAZOO, KALKASKA, KENT, LAKE, LEELANAU, MANISTEE, MASON, MECOSTA, MISSAUKEE, MONTCALM, MUSKEGON, NEWAYGO, OCEANA, OSCEOLA, OTTAWA, ST. JOSEPH, VAN BUREN AND WEXFORD COUNTIES:.\$ 35.55 33.14  
Bay, Genesee, Lapeer,  
Livingston (east of  
Burkhardt Road), Macomb,  
Midland, Oakland, Saginaw,  
St. Clair, The University

of Michigan, Washtenaw (east of U.S. 23) & Wayne...	\$ 25.81	26.43
IRONWORKER		
Ornamental and Structural...	\$ 34.50	38.44
Reinforcing.....	\$ 33.43	37.15

-----  
IRON0055-005 07/01/2022

LENAWEE AND MONROE COUNTIES:

	Rates	Fringes
IRONWORKER		
Pre-engineered metal buildings.....	\$ 23.59	19.35
All other work.....	\$ 33.00	27.20

-----  
IRON0292-003 06/01/2020

BERRIEN AND CASS COUNTIES:

	Rates	Fringes
IRONWORKER (Including pre-engineered metal building erector).....		
	\$ 31.75	22.84

-----  
LABO0005-006 10/01/2022

	Rates	Fringes
--	-------	---------

Laborers - hazardous waste  
abatment: (ALCONA, ALPENA, ANTRIM, BENZIE, CHARLEVOIX, CHEBOYGAN, CRAWFORD, EMMET,  
GRAND TRAVERSE, IOSCO, KALKASKA, LEELANAU, MISSAUKEE, MONTMORENCY, OSCODA, OTSEGO,  
PRESQUE ISLE AND WEXFORD COUNTIES - Zone

10)

Levels A, B or C.....	\$ 17.45 **	12.75
class b.....	\$ 18.64	12.90
Work performed in conjunction with site preparation not requiring the use of personal protective equipment;		
Also, Level D.....	\$ 16.45 **	12.75
class a.....	\$ 17.64 **	12.90

Zone 10

Laborers - hazardous waste  
abatment: (ALGER, BARAGA, CHIPPEWA, DELTA, DICKINSON, GOGEBIC, HOUGHTON, IRON, KEWEENAW,  
LUCE, MACKINAC, MARQUETTE, MENOMINEE, ONTONAGON AND SCHOOLCRAFT COUNTIES - Zone 11)

Levels A, B or C.....	\$ 25.18	12.90
Work performed in conjunction with site preparation not requiring the use of personal protective equipment;		
Also, Level D.....	\$ 22.58	12.90

Laborers - hazardous waste  
abatment: (ALLEGAN, BARRY, ERRIEN, BRANCH, CALHOUN, CASS, IONIA COUNTY (except the city of Portland);  
KALAMAZOO, KENT, LAKE, MANISTEE, MASON, MECOSTA, MONTCALM, MUSKEGON, NEWAYGO, OCEANA,  
OSCEOLA, OTTAWA, ST. JOSEPH AND VAN BUREN COUNTIES - Zone 9)

Levels A, B or C.....	\$ 21.88	13.26
Work performed in conjunction with site preparation not requiring the use of personal		

protective equipment; Also, Level D.....	\$ 20.80	12.90
Laborers - hazardous waste abatement: (ARENAC, BAY, CLARE, GLADWIN, GRATIOT, HURON, ISABELLA, MIDLAND, OGEMAW, ROSCOMMON, SAGINAW AND TUSCOLA COUNTIES - Zone 8)		
Levels A, B or C.....	\$ 23.74	12.95
Work performed in conjunction with site preparation not requiring the use of personal protective equipment; Also, Level D.....		
	\$ 20.80	12.90
Laborers - hazardous waste abatement: (CLINTON, EATON AND INGHAM COUNTIES; IONIA COUNTY (City of Portland); LIVINGSTON COUNTY (west of Oak Grove Rd., including the City of Howell) - Zone 6)		
Levels A, B or C.....	\$ 26.33	12.95
Work performed in conjunction with site preparation not requiring the use of personal protective equipment; Also, Level D.....		
	\$ 24.64	12.90
Laborers - hazardous waste abatement: (GENESEE, LAPEER AND SHIAWASSEE COUNTIES - Zone 7)		
Levels A, B or C.....	\$ 24.20	13.80
Work performed in conjunction with site preparation not requiring the use of personal protective equipment; Also, Level D.....		
	\$ 23.20	13.80
Laborers - hazardous waste abatement: (HILLSDALE, JACKSON AND LENAWEE COUNTIES Zone 4)		
Levels A, B or C.....	\$ 27.13	14.95
Work performed in conjunction with site preparation not requiring the use of personal protective equipment; Also, Level D.....		
	\$ 24.17	12.90
Laborers - hazardous waste abatement: (LIVINGSTON COUNTY (east of Oak Grove Rd. and south of M-59, excluding the city of Howell); AND WASHTENAW COUNTY - Zone 3)		
Levels A, B or C.....	\$ 29.93	14.20
Work performed in conjunction with site preparation not requiring the use of personal protective equipment; Also, Level D.....		
	\$ 28.93	14.20
Laborers - hazardous waste abatement: (MACOMB AND WAYNE COUNTIES - Zone 1)		
Levels A, B or C.....	\$ 29.93	16.90
Work performed in conjunction with site preparation not requiring the use of personal protective equipment; Also, Level D.....		
	\$ 28.93	16.90
Laborers - hazardous waste abatement: (MONROE COUNTY - Zone 4)		
Levels A, B or C.....	\$ 31.75	14.90
Work performed in conjunction with site		

preparation not requiring the use of personal protective equipment; Also, Level D.....\$ 31.75	14.90
Laborers - hazardous waste abatement: (OAKLAND COUNTY and the Northeast portion of LIVINGSTON COUNTY bordered by Oak Grove Road on the West and M-59 on the South - Zone 2)	
Level A, B, C.....\$ 29.93	16.90
Work performed in conjunction with site preparation not requiring the use of personal protective equipment; Also, Level D.....\$ 28.93	
16.90	
Laborers - hazardous waste abatement: (SANILAC AND ST. CLAIR COUNTIES - Zone 5)	
Levels A, B or C.....\$ 26.21	16.62
Work performed in conjunction with site preparation not requiring the use of personal protective equipment; Also, Level D.....\$ 24.75	
16.35	

LABO0259-001 09/01/2024

AREA 1: MACOMB, OAKLAND AND WAYNE COUNTIES AREA 2: ALCONA, ALGER, ALLEGAN, ALPENA, ANTRIM, ARENAC, BARAGA, BARRY, BAY, BENZIE, BERRIEN, BRANCH, CALHOUN, CASS, CHARLEVOIX, CHEBOYGAN, CHIPPEWA, CLARE, CLINTON, CRAWFORD, DELTA, DICKINSON, EATON, EMMET, GENESEE, GLADWIN, GOGEBIC, GRAND TRAVERSE, GRATIOT, HILLSDALE, HOUGHTON, HURON, INGHAM, IONIA, IOSCO, IRON, ISABELLA, JACKSON, KALAMAZOO, KALKASKA, KENT, KEWEENAW, LAKE, LAPEER, LEELANAU, LENAWEE, LIVINGSTON, LUCE, MACKINAC, MANISTEE, MARQUETTE, MASON, MECOSTA, MENOMINEE, MIDLAND, MISSAUKEE, MONROE, MONTCALM, MONTMORENCY, MUSKEGON, NEWAYGO, OCEANA, OGEMAW, ONTONAGON, OSCEOLA, OSCODA, OTSEGO, OTTAWA, PRESQUE ISLE, ROSCOMMON, SAGINAW, ST. CLARE, ST. JOSEPH, SANILAC, SCHOOLCRAFT, SHIAWASSEE, TUSCOLA, VAN BUREN, WASHTENAW AND WEXFORD COUNTIES

Rates Fringes

Laborers - tunnel, shaft and caisson:	
AREA 1	
GROUP 1.....\$ 27.86	22.11
GROUP 2.....\$ 29.86	22.11
GROUP 3.....\$ 25.86	22.11
GROUP 4.....\$ 23.97	16.93
GROUP 5.....\$ 24.22	16.93
GROUP 6.....\$ 24.55	16.93
GROUP 7.....\$ 17.83	16.93
AREA 2	
GROUP 1.....\$ 30.00	17.45
GROUP 2.....\$ 32.00	17.45
GROUP 3.....\$ 28.00	17.45
GROUP 4.....\$ 29.57	16.93
GROUP 5.....\$ 25.76	16.93
GROUP 6.....\$ 26.07	16.93
GROUP 7.....\$ 25.57	16.93

SCOPE OF WORK: Tunnel, shaft and caisson work of every type and description and all operations incidental thereto, including, but not limited to, shafts and tunnels for sewers, water, subways, transportation, diversion, sewerage, caverns, shelters, aquafers, reservoirs, missile silos and steel sheeting for underground construction.

TUNNEL LABORER CLASSIFICATIONS

GROUP 1: Tunnel, shaft and caisson laborer, dump, shanty, hog house tender, testing (on gas) and watchman

GROUP 2: Manhole, headwall, catch basin builder, bricklayer tender, mortar machine and material mixer

GROUP 3: Air tool operator (jackhammer, bush hammer and grinder), first bottom, second bottom, cage tender, car pusher, carrier, concrete, concrete form, concrete repair, cement invert laborer, cement finisher, concrete shoveler, conveyor, floor, gasoline and electric tool operator, gunite, grout operator, welder, heading dinky person, inside lock tender, pea gravel operator, pump, outside lock tender, scaffold, top signal person, switch person, track, tugger, utility person, vibrator, winch operator, pipe jacking, wagon drill and air track operator and concrete saw operator (under 40 h.p.)

GROUP 4: Tunnel, shaft and caisson mucker, bracer, liner plate, long haul dinky driver and well point

GROUP 5: Tunnel, shaft and caisson miner, drill runner, key board operator, power knife operator, reinforced steel or mesh (e.g. wire mesh, steel mats, dowel bars, etc.)

GROUP 6: Dynamite and powder

GROUP 7: Restoration laborer, seeding, sodding, planting, cutting, mulching and top soil grading; and the restoration of property such as replacing mailboxes, wood chips, planter boxes, flagstones, etc.

-----  
LABO0334-001 09/01/2024

Rates Fringes

Laborers - open cut:

ZONE 1 - MACOMB, OAKLAND AND WAYNE COUNTIES:

GROUP 1.....	\$ 27.71	22.11
GROUP 2.....	\$ 29.71	22.11
GROUP 3.....	\$ 25.87	22.11
GROUP 4.....	\$ 23.71	16.72
GROUP 5.....	\$ 24.17	16.72
GROUP 6.....	\$ 22.00	16.72
GROUP 7.....	\$ 17.84	16.72

ZONE 2 - LIVINGSTON COUNTY

(east of M-151 (Oak Grove Rd.)); MONROE AND

WASHTENAW COUNTIES:

GROUP 1.....	\$ 29.65	17.45
GROUP 2.....	\$ 31.65	17.45
GROUP 3.....	\$ 27.65	17.45
GROUP 4.....	\$ 25.10	16.72
GROUP 5.....	\$ 25.25	16.72
GROUP 6.....	\$ 22.55	16.72
GROUP 7.....	\$ 22.11	16.72

ZONE 3 - CLINTON, EATON, GENESEE, HILLSDALE AND INGHAM COUNTIES; IONIA

COUNTY (City of Portland);

JACKSON, LAPEER AND

LENAWEE COUNTIES;

LIVINGSTON COUNTY (west of M-151 Oak Grove Rd.);

SANILAC, ST. CLAIR AND

SHIAWASSEE COUNTIES:

GROUP 1.....	\$ 27.84	17.45
GROUP 2.....	\$ 29.84	17.45
GROUP 3.....	\$ 25.84	17.45
GROUP 4.....	\$ 23.30	16.72
GROUP 5.....	\$ 23.44	16.72

GROUP 6.....	\$ 20.74	16.72
GROUP 7.....	\$ 22.23	16.72
ZONE 4 - ALCONA, ALLEGAN, ALPENA, ANTRIM, ARENAC, BARRY, BAY, BENZIE, BERRIEN, BRANCH, CALHOUN, CASS, CHARLEVOIX, CHEBOYGAN, CLARE, CRAWFORD, EMMET, GLADWIN, GRAND TRAVERSE, GRATIOT AND HURON COUNTIES; IONIA COUNTY (EXCEPT THE CITY OF PORTLAND); IOSCO, ISABELLA, KALAMAZOO, KALKASKA, KENT, LAKE, LEELANAU, MANISTEE, MASON, MECOSTA, MIDLAND, MISSAUKEE, MONTCALM, MONTMORENCY, MUSKEGON, NEWAYGO, OCEANA, OGEMAW, OSCEOLA, OSCODA, OTSEGO, OTTAWA, PRESQUE ISLE, ROSCOMMON, SAGINAW, ST. JOSEPH, TUSCOLA, VAN BUREN AND WEXFORD COUNTIES:		
GROUP 1.....	\$ 26.32	17.95
GROUP 2.....	\$ 28.32	17.95
GROUP 3.....	\$ 24.32	17.95
GROUP 4.....	\$ 22.33	16.72
GROUP 5.....	\$ 22.45	16.72
GROUP 6.....	\$ 19.67	16.72
GROUP 7.....	\$ 22.30	16.72
ZONE 5 - ALGER, BARAGA, CHIPPEWA, DELTA, DICKINSON, GOGEBIC, HOUGHTON, IRON, KEWEENAW, LUCE, MACKINAC, MARQUETTE, MENOMINEE, ONTONAGON AND SCHOOLCRAFT COUNTIES:		
GROUP 1.....	\$ 26.09	18.45
GROUP 2.....	\$ 28.09	18.45
GROUP 3.....	\$ 24.09	18.45
GROUP 4.....	\$ 22.56	16.72
GROUP 5.....	\$ 22.64	16.72
GROUP 6.....	\$ 19.99	16.72
GROUP 7.....	\$ 22.45	16.72

SCOPE OF WORK:

Open cut construction work shall be construed to mean work which requires the excavation of earth including industrial, commercial and residential building site excavation and preparation, land balancing, demolition and removal of concrete and underground appurtenances, grading, paving, sewers, utilities and improvements; retention, oxidation, flocculation and irrigation facilities, and also including but not limited to underground piping, conduits, steel sheeting for underground construction, and all work incidental thereto, and general excavation. For all areas except the Upper Peninsula, open cut construction work shall also be construed to mean waterfront work, piers, docks, seawalls, breakwalls, marinas and all incidental work. Open cut construction work shall not include any structural modifications, alterations, additions and repairs to buildings, or highway work, including roads, streets, bridge construction and parking lots or steel erection work and excavation for the building itself and back filling inside of and within 5 ft. of the building and foundations, footings and piers for the building. Open cut construction work shall not include any work covered under Tunnel, Shaft and Caisson work.

OPEN CUT LABORER CLASSIFICATIONS

GROUP 1: Construction laborer

GROUP 2: Mortar and material mixer, concrete form person, signal person, well point person, manhole, headwall and catch basin builder, headwall, seawall, breakwall and dock builder

GROUP 3: Air, gasoline and electric tool operator, vibrator operator, driller, pump person, tar kettle operator, bracer, rodder, reinforced steel or mesh person (e.g., wire mesh, steel mats, dowel bars, etc.), welder, pipe jacking and boring person, wagon drill and air track operator and concrete saw operator (under 40 h.p.), windlass and tugger person and directional boring person

GROUP 4: Trench or excavating grade person

GROUP 5: Pipe layer (including crock, metal pipe, multi-plate or other conduits)

GROUP 6: Grouting man, audio-visual television operations and all other operations in connection with closed circuit television inspection, pipe cleaning and pipe relining work and the installation and repair of water service pipe and appurtenances

GROUP 7: Restoration laborer, seeding, sodding, planting, cutting, mulching and top soil grading; and the restoration of property such as replacing mailboxes, wood chips, planter boxes, flagstones, etc.

LABO0465-001 06/01/2024

LABORER: Highway, Bridge and Airport Construction

AREA 1: GENESEE, MACOMB, MONROE, OAKLAND, WASHTENAW AND WAYNE COUNTIES

AREA 2: ALLEGAN, BARRY, BAY, BERRIEN, BRANCH, CALHOUN, CASS, CLINTON, EATON, GRATIOT, HILLSDALE, HURON, INGHAM, JACKSON, KALAMAZOO, LAPEER, LENAWEE, LIVINGSTON, MIDLAND, MUSKEGON, SAGINAW, SANILAC, SHIAWASSEE, ST. CLAIR, ST. JOSEPH, TUSCOLA AND VAN BUREN COUNTIES

AREA 3: ALCONA, ALPENA, ANTRIM, ARENAC, BENZIE, CHARLEVOIX, CHEBOYGAN, CLARE, CRAWFORD, EMMET, GLADWIN, GRAND TRAVERSE, IONIA, IOSCO, ISABELLA, KALKASKA, KENT, LAKE, LEELANAU, MANISTEE, MASON, MECOSTA, MISSAUKEE, MONTCALM, MONTMORENCY, NEWAYGO, OCEANA, OGEMAW, OSCEOLA, OSCODA, OTSEGO, OTTAWA, PRESQUE ISLE, ROSCOMMON AND WEXFORD COUNTIES

AREA 4: ALGER, BARAGA, CHIPPEWA, DELTA, DICKINSON, GOGEBIC, HOUGHTON, IRON, KEWEENAW, LUCE, MACKINAC, MARQUETTE, MENOMINEE, ONTONAGON AND SCHOOLCRAFT COUNTIES

	Rates	Fringes
LABORER (AREA 1)		
GROUP 1.....	\$ 34.01	14.45
GROUP 2.....	\$ 34.14	14.45
GROUP 3.....	\$ 34.32	14.45
GROUP 4.....	\$ 34.40	14.45
GROUP 5.....	\$ 34.61	14.45
GROUP 6.....	\$ 34.91	14.45
LABORER (AREA 2)		
GROUP 1.....	\$ 31.87	14.45
GROUP 2.....	\$ 32.07	14.45
GROUP 3.....	\$ 32.31	14.45
GROUP 4.....	\$ 32.66	14.45
GROUP 5.....	\$ 32.53	14.45
GROUP 6.....	\$ 32.87	14.45
LABORER (AREA 3)		
GROUP 1.....	\$ 31.12	14.45
GROUP 2.....	\$ 31.33	14.45
GROUP 3.....	\$ 31.62	14.45
GROUP 4.....	\$ 32.06	14.45
GROUP 5.....	\$ 31.68	14.45
GROUP 6.....	\$ 32.11	14.45
LABORER (AREA 4)		
GROUP 1.....	\$ 32.02	14.45
GROUP 2.....	\$ 31.73	14.45
GROUP 3.....	\$ 32.52	14.45
GROUP 4.....	\$ 32.96	14.45
GROUP 5.....	\$ 32.58	14.45
GROUP 6.....	\$ 33.01	14.45

LABORER CLASSIFICATIONS

GROUP 1: Asphalt shoveler or loader; asphalt plant misc.; burlap person; yard person; dumper (wagon, truck, etc.); joint filling laborer; miscellaneous laborer; unskilled laborer; sprinkler laborer; form setting laborer; form stripper; pavement reinforcing; handling and placing (e.g., wire mesh, steel mats, dowel bars); mason's tender or bricklayer's tender on manholes; manhole builder; headwalls, etc.; waterproofing, (other than buildings) seal coating and slurry mix, shoring, underpinning; pressure grouting; bridge pin and hanger removal; material recycling laborer; horizontal paver laborer (brick, concrete, clay, stone and asphalt); ground stabilization and modification laborer; grouting; waterblasting; top person; railroad track and trestle laborer; carpenters' tender; guard rail builders' tender; earth retention barrier and wall and M.S.E. wall installer's tender; highway and median installer's tender (including sound, retaining, and crash barriers); fence erector's tender; asphalt raker tender; sign installer; remote control operated equipment.

GROUP 2: Mixer operator (less than 5 sacks); air or electric tool operator (jackhammer, etc.); spreader; boxperson (asphalt, stone, gravel); concrete paddler; power chain saw operator; paving batch truck dumper; tunnel mucker (highway work only); concrete saw (under 40 h.p.) and dry pack machine; roto-mill grounds person.

GROUP 3: Tunnel miner (highway work only); finishers tenders; guard rail builders; highway and median barrier installer; earth retention barrier and wall and M.S.E. wall installer's (including sound, retaining and crash barriers); fence erector; bottom person; powder person; wagon drill and air track operator; diamond and core drills; grade checker; certified welders; curb and side rail setter's tender.

GROUP 4: Asphalt raker

GROUP 5: Pipe layers, oxy-gun

GROUP 6: Line-form setter for curb or pavement; asphalt screed checker/screw man on asphalt paving machines.

-----  
LABO1076-005 04/01/2024

MICHIGAN STATEWIDE

	Rates	Fringes
LABORER (DISTRIBUTION WORK)		
Zone 1.....	\$ 27.16	13.45
Zone 2.....	\$ 25.42	13.45
Zone 3.....	\$ 23.55	13.45
Zone 4.....	\$ 22.92	13.45
Zone 5.....	\$ 22.95	13.45

DISTRIBUTION WORK - The construction, installation, treating and reconditioning of distribution pipelines transporting coal, oil, gas or other similar materials, vapors or liquids, including pipelines within private property boundaries, up to and including the meter settings on residential, commercial, industrial, institutional, private and public structures. All work covering pumping stations and tank farms not covered by the Building Trades Agreement. Other distribution lines with the exception of sewer, water and cable television are included.

Underground Duct Layer Pay: \$.40 per hour above the base pay rate.

- Zone 1 - Macomb, Oakland and Wayne
- Zone 2 - Monroe and Washtenaw
- Zone 3 - Bay, Genesee, Lapeer, Midland, Saginaw, Sanilac, Shiawassee and St. Clair
- Zone 4 - Alger, Baraga, Chippewa, Delta, Dickinson, Gogebic, Houghton, Iron, Keweenaw, Luce, Mackinac, Marquette, Menominee, Ontonagon and Schoolcraft
- Zone 5 - Remaining Counties in Michigan

-----  
PAIN0022-002 07/01/2008

HILLSDALE, JACKSON AND LENAWEE COUNTIES; LIVINGSTON COUNTY (east of the eastern city limits of Howell, not including the city of Howell, north to the Genesee County line and south to the Washtenaw County line); MACOMB, MONROE, OAKLAND, WASHTENAW AND WAYNE COUNTIES:

	Rates	Fringes
PAINTER.....	\$ 25.06	14.75

FOOTNOTES: For all spray work and journeyman rigging for spray work, also blowing off, \$0.80 per hour additional (applies only to workers doing rigging for spray work on off the floor work. Does not include setting up or moving rigging on floor surfaces, nor does it apply to workers engaged in covering up or tending spray equipment. For all sandblasting and spray work performed on highway bridges, overpasses, tanks or steel, \$0.80 per hour additional. For all brushing, cleaning and other preparatory work (other than spraying or steeplejack work) at scaffold heights of fifty (50) feet from the ground or higher, \$0.50 per hour additional. For all preparatorial work and painting performed on open steel under forty (40) feet when no scaffolding is involved, \$0.50 per hour additional. For all swing stage work-window jacks and window belts-exterior and interior, \$0.50 per hour additional. For all spray work and sandblaster work to a scaffold height of forty (40) feet above the floor level, \$0.80 per hour additional. For all preparatorial work and painting on all highway bridges or overpasses up to forty (40) feet in height, \$0.50 per hour

additional. For all steeplejack work performed where the elevation is forty (40) feet or more, \$1.25 per hour additional.

-----  
 PAIN0312-001 06/01/2018

EXCLUDES: ALLEGAN COUNTY (Townships of Dorr, Fillmore, Heath, Hopkins, Laketown, Leighton, Manlius, Monterey, Overisel, Salem, Saugatuck and Wayland); INCLUDES: Barry, Berrien, Branch, Calhoun, Cass, Hillsdale, Kalamazoo, St. Joseph, Van Buren

Rates Fringes

PAINTER

Brush and roller.....	\$ 23.74	13.35
Spray, Sandblast, Sign Painting.....	\$ 24.94	13.35

-----  
 PAIN0845-003 05/10/2018

CLINTON COUNTY; EATON COUNTY (does not include the townships of Bellevue and Olivet); INGHAM COUNTY; IONIA COUNTY (east of Hwy. M 66); LIVINGSTON COUNTY (west of the eastern city limits of Howell, including the city of Howell, north to the Genesee County line and south to the Washtenaw County line); AND SHIAWASSEE COUNTY (Townships of Bennington, Laingsbury and Perry):

Rates Fringes

PAINTER.....	\$ 25.49	13.74
--------------	----------	-------

-----  
 PAIN0845-015 05/10/2018

MUSKEGON COUNTY; NEWAYGO COUNTY (except the Townships of Barton, Big Prairie, Brooks, Croton, Ensley, Everett, Goodwell, Grant, Home, Monroe, Norwich and Wilcox); OCEANA COUNTY; OTTAWA COUNTY (except the townships of Allendale, Blendone, Chester, Georgetown, Holland, Jamestown, Olive, Park, Polkton, Port Sheldon, Tallmadge, Wright and Zeeland):

Rates Fringes

PAINTER.....	\$ 25.49	13.74
--------------	----------	-------

-----  
 PAIN0845-018 05/10/2018

ALLEGAN COUNTY (Townships of Dorr, Fillmore, Heath, Hopkins, Laketown, Leighton, Manlius, Monterey, Overisel, Salem, Saugatuck and Wayland); IONIA COUNTY (west of Hwy. M-66); KENT, MECOSTA AND MONTCALM COUNTIES; NEWAYGO COUNTY (Townships of Barton, Big Prairie, Brooks, Croton, Ensley, Everett, Goodwell, Grant, Home, Monroe, Norwich and Wilcox); OSCEOLA COUNTY (south of Hwy. #10); OTTAWA COUNTY (Townships of Allendale, Blendone, Chester, Georgetown, Holland, Jamestown, Olive, Park, Polkton, Port Sheldon, Tallmadge, Wright and Zeeland):

Rates Fringes

PAINTER.....	\$ 25.49	13.74
--------------	----------	-------

FOOTNOTES: Lead abatement work: \$1.00 per hour additional.

-----  
 PAIN1011-003 06/02/2022

ALGER, BARAGA, CHIPPEWA, DELTA, DICKINSON, GOGEBIC, HOUGHTON, IRON, KEWEENAW, LUCE, MACKINAC, MARQUETTE, MENOMINEE, ONTONAGON AND SCHOOLCRAFT COUNTIES:

Rates Fringes

PAINTER.....	\$ 24.66	14.99
--------------	----------	-------

FOOTNOTES: High pay (bridges, overpasses, watertower): 30 to 80 ft.: \$.65 per hour additional. 80 ft. and over: \$1.30 per hour additional.

-----  
 PAIN1474-002 06/01/2010

HURON COUNTY; LAPEER COUNTY (east of Hwy. M-53); ST. CLAIR, SANILAC AND TUSCOLA COUNTIES:

	Rates	Fringes
PAINTER.....	\$ 23.79	12.02

FOOTNOTES: Lead abatement work: \$1.00 per hour additional. Work with any hazardous material: \$1.00 per hour additional. Sandblasting, steam cleaning and acid cleaning: \$1.00 per hour additional. Ladder work at or above 40 ft., scaffold work at or above 40 ft., swing stage, boatswain chair, window jacks and all work performed over a falling height of 40 ft.: \$1.00 per hour additional. Spray gun work, pick pullers and those handling needles, blowing off by air pressure, and any person rigging (setting up and moving off the ground): \$1.00 per hour additional. Steeplejack, tanks, gas holders, stacks, flag poles, radio towers and beacons, power line towers, bridges, etc.: \$1.00 per hour additional, paid from the ground up.

-----  
 PAIN1803-003 06/01/2024

ALCONA, ALPENA, ANTRIM, ARENAC, BAY, BENZIE, CHARLEVOIX, CHEBOYGAN, CLARE, CRAWFORD, EMMET, GLADWIN, GRAND TRAVERSE, GRATIOT, IOSCO, ISABELLA, KALKASKA, LAKE, LEELANAU, MANISTEE, MASON, MIDLAND, MISSAUKEE, MONTMORENCY AND OGEMAW COUNTIES; OSCEOLA COUNTY (north of Hwy. #10); OSCODA, OTSEGO, PRESQUE ISLE, ROSCOMMON, SAGINAW AND WEXFORD COUNTIES:

	Rates	Fringes
PAINTER		
Work performed on water, bridges over water or moving traffic, radio and powerline towers, elevated tanks, steeples, smoke stacks over 40 ft. of falling heights, recovery of lead-based paints and any work associated with industrial plants, except maintenance of industrial plants.....	\$ 29.35	19.05
All other work, including maintenance of industrial plant.....	\$ 29.35	19.05

FOOTNOTES: Spray painting, sandblasting, blowdown associated with spraying and blasting, water blasting and work involving a swing stage, boatswain chair or spider: \$1.00 per hour additional. All work performed inside tanks, vessels, tank trailers, railroad cars, sewers, smoke stacks, boilers or other spaces having limited egress not including buildings, opentop tanks, pits, etc.: \$1.25 per hour additional.

-----  
 PLAS0514-001 06/01/2023

ZONE 1: GENESEE, LIVINGSTON, MACOMB, MONROE, OAKLAND, SAGINAW, WASHTENAW AND WAYNE COUNTIES

ZONE 2: ALCONA, ALGER, ALLEGAN, ALPENA, ANTRIM, ARENAC, BARAGA, BARRY, BAY, BENZIE, BERRIEN, BRANCH, CALHOUN, CASS, CHARLEVOIX, CHEBOYGAN, CHIPPEWA, CLARE, CLINTON, CRAWFORD, DELTA, DICKINSON, EATON, EMMET, GLADWIN, GOGEBIC, GRAND TRAVERSE, GRATIOT, HILLSDALE, HOUGHTON, HURON, INGHAM, IONIA, IOSCO, IRON, ISABELLA, JACKSON, KALAMAZOO, KALKASKA, KENT, KEWEENAW, LAKE, LAPEER, LEELANAU, LENAWEE, LUCE, MACKINAC, MANISTEE, MARQUETTE, MASON, MECOSTA, MENOMINEE, MIDLAND, MISSAUKEE, MONTCALM, MONTMORENCY, MUSKEGON, NEWAYGO, OCEANA,

OGEMAW, ONTONAGON, OSCEOLA, OSCODA, OTSEGO, OTTAWA, PRESQUE ISLE, ROSCOMMON, SANILAC, SCHOOLCRAFT, SHIAWASSEE, ST. CLAIR, ST. JOSEPH, TUSCOLA, VAN BUREN AND WEXFORD COUNTIES

Rates Fringes

CEMENT MASON/CONCRETE FINISHER

ZONE 1.....	\$ 33.00	18.51
ZONE 2.....	\$ 31.50	18.51

-----  
 PLUM0190-003 05/01/2015

ALCONA, ALGER, ALLEGAN, ALPENA, ANTRIM, ARENAC, BARAGA, BARRY, BAY, BENZIE, BERRIEN, BRANCH, CALHOUN, CASS, CHARLEVOIX, CHEBOYGAN, CHIPPEWA, CLARE, CLINTON, CRAWFORD, DELTA, DICKINSON, EATON, EMMET, GENESEE, GLADWIN, GOGEBIC, GRAND TRAVERSE, GRATIOT, HILLSDALE, HOUGHTON, HURON, INGHAM, IONIA, IOSCO, IRON, ISABELLA, JACKSON, KALAMAZOO, KALKASKA, KENT, KEWEENAW, LAKE, LAPEER, LEELANAU, LENAWEE, LIVINGSTON, LUCE, MACKINAC, MACOMB, MANISTEE, MARQUETTE, MASON, MECOSTA, MENOMINEE, MIDLAND, MISSAUKEE, MONTCALM, MONTMORENCY, MONROE, MUSKEGON, NEWAYGO, OAKLAND, OCEANA, OGEMAW, ONTONAGON, OSCEOLA, OSCODA, OTSEGO, OTTAWA, PRESQUE ISLE, ROSCOMMON, SAGINAW, ST. CLARE, ST. JOSEPH, SANILAC, SCHOOLCRAFT, SHIAWASSEE, TUSCOLA, VAN BUREN, WASHTENAW, WAYNE AND WEXFORD COUNTIES

Rates Fringes

Plumber/Pipefitter - gas  
 distribution pipeline:

Welding in conjunction with gas distribution pipeline work.....	\$ 33.03	20.19
All other work:.....	\$ 24.19	12.28

-----  
 TEAM0007-004 06/01/2024

AREA 1: ALCONA, ALGER, ALLEGAN, ALPENA, ANTRIM, ARENAC, BARAGA, BARRY, BAY, BENZIE, BERRIEN, BRANCH, CALHOUN, CASS, CHARLEVOIX, CHEBOYGAN, CHIPPEWA, CLARE, CLINTON, CRAWFORD, DELTA, DICKINSON, EATON, EMMET, GLADWIN, GOGEBIC, GRAND TRAVERSE, GRATIOT, HILLSDALE, HOUGHTON, HURON, INGHAM, IONIA, IOSCO, IRON, ISABELLA, JACKSON, KALAMAZOO, KALKASKA, KENT, KEWEENAW, LAKE, LAPEER, LEELANAU, LENAWEE, LUCE, MACKINAC, MANISTEE, MARQUETTE, MASON, MECOSTA, MENOMINEE, MIDLAND, MISSAUKEE, MONTCALM, MONTMORENCY, MUSKEGON, NEWAYGO, OCEANA, OGEMAW, ONTONAGON, OSCEOLA, OSCODA, OTSEGO, OTTAWA, PRESQUE ISLE, ROSCOMMON, SAGINAW, SANILAC, SCHOOLCRAFT, SHIAWASSEE, ST. CLAIR, ST. JOSEPH, TUSCOLA, VAN BUREN AND WEXFORD COUNTIES

AREA 2: GENESEE, LIVINGSTON, MACOMB, MONROE, OAKLAND, WASHTENAW AND WAYNE COUNTIES

Rates Fringes

TRUCK DRIVER

AREA 1

Euclids, double bottoms and lowboys.....	\$ 32.55	.75 + a+b
Trucks under 8 cu. yds.....	\$ 32.30	.75 + a+b
Trucks, 8 cu. yds. and over.....	\$ 32.40	.75 + a+b

AREA 2

Euclids, double bottoms and lowboys.....	\$ 32.65	.75 + a+b
Trucks under 8 cu. yds.....	\$ 32.40	.75 + a+b
Trucks, 8 cu. yds. and over.....	\$ 32.50	.75 + a+b

Footnote:

- a. \$470.70 per week
- b. \$68.70 daily

-----  
 TEAM0247-004 04/01/2013

AREA 1: ALCONA, ALGER, ALLEGAN, ALPENA, ANTRIM, ARENAC, BARAGA, BARRY, BAY, BENZIE, BERRIEN, BRANCH, CALHOUN, CASS, CHARLEVOIX, CHEBOYGAN, CHIPPEWA, CLARE, CLINTON, CRAWFORD, DELTA, DICKINSON, EATON, EMMET, GLADWIN, GOGEBIC, GRAND TRAVERSE, GRATIOT, HILLSDALE, HOUGHTON, HURON, INGHAM, IONIA, IOSCO, IRON, ISABELLA, JACKSON, KALAMAZOO, KALKASKA, KENT, KEWEENAW, LAKE, LAPEER, LEELANAU, LENAWEE, LUCE, MACKINAC, MANISTEE, MARQUETTE, MASON, MECOSTA, MENOMINEE, MIDLAND, MISSAUKEE, MONTCALM, MONTMORENCY, MUSKEGON, NEWAYGO, OCEANA, OGEMAW, ONTONAGON, OSCEOLA, OSCODA, OTSEGO, OTTAWA, PRESQUE ISLE, ROSCOMMON, SANILAC, SCHOOLCRAFT, SHIAWASSEE, SAGINAW, ST. CLAIR, ST. JOSEPH, TUSCOLA, VAN BUREN AND WEXFORD COUNTIES

AREA 2: GENESEE, LIVINGSTON, MACOMB, MONROE, OAKLAND, WASHTENAW AND WAYNE COUNTIES

	Rates	Fringes
Sign Installer		
AREA 1		
GROUP 1.....	\$ 21.78	11.83
GROUP 2.....	\$ 25.27	11.8375
AREA 2		
GROUP 1.....	\$ 22.03	11.83
GROUP 2.....	\$ 25.02	11.8375

FOOTNOTE:

a. \$132.70 per week, plus \$17.80 per day.

SIGN INSTALLER CLASSIFICATIONS:

GROUP 1: performs all necessary labor and uses all tools required to construct and set concrete forms required in the installation of highway and street signs

GROUP 2: performs all miscellaneous labor, uses all hand and power tools, and operates all other equipment, mobile or otherwise, required for the installation of highway and street signs

-----  
TEAM0247-010 04/01/2018

AREA 1: LAPEER AND SHIAWASSEE COUNTIES

AREA 2: GENESEE, MACOMB, MONROE, OAKLAND, ST. CLAIR, WASHTENAW AND WAYNE COUNTIES

	Rates	Fringes
TRUCK DRIVER (Underground construction)		
AREA 1		
GROUP 1.....	\$ 23.82	19.04
GROUP 2.....	\$ 23.91	19.04
GROUP 3.....	\$ 24.12	19.04
AREA 2		
GROUP 1.....	\$ 24.12	19.04
GROUP 2.....	\$ 24.26	19.04
GROUP 3.....	\$ 24.45	19.04

PAID HOLIDAYS: New Year's Day, Memorial Day, Fourth of July, Labor Day, Thanksgiving Day and Christmas Day.

SCOPE OF WORK: Excavation, site preparation, land balancing, grading, sewers, utilities and improvements; also including but not limited to, tunnels, underground piping, retention, oxidation, flocculation facilities, conduits, general excavation and steel sheeting for underground construction. Underground construction work shall not include any structural modifications, alterations, additions and repairs to buildings or highway work, including roads, streets, bridge construction and parking lots or steel erection.

TRUCK DRIVER CLASSIFICATIONS

GROUP 1: Truck driver on all trucks (EXCEPT dump trucks of 8 cubic yards capacity or over, pole trailers, semis, low boys, Euclid, double bottom and fuel trucks)

GROUP 2: Truck driver on dump trucks of 8 cubic yards capacity or over, pole trailers, semis and fuel trucks

GROUP 3: Truck driver on low boy, Euclid and double bottom

-----  
SUMI2002-001 05/01/2002

	Rates	Fringes
FLAG PERSON.....	\$ 10.10 **	0.00
LINE PROTECTOR (ZONE 1: GENESEE, MACOMB, MONROE, OAKLAND, WASHTENAW AND WAYNE)....	\$ 22.89	13.45
LINE PROTECTOR (ZONE 2: STATEWIDE (EXCLUDING GENESEE, MACOMB, MONROE, OAKLAND, WASHTENAW AND WAYNE).....	\$ 20.19	13.45
Pavement Marking Machine (ZONE 1: GENESEE, MACOMB, MONROE, OAKLAND, WASHTENAW AND WAYNE COUNTIES) Group 1.....	\$ 30.52	13.45
Pavement Marking Machine (ZONE 1: GENESEE, MACOMB, MONROE, OAKLAND, WASHTENAW AND WAYNE) Group 2.....	\$ 27.47	13.45
Pavement Marking Machine (ZONE 2: STATEWIDE (EXCLUDING GENESEE, MACOMB, MONROE, OAKLAND, WASHTENAW AND WAYNE COUNTIES) Group 1.....	\$ 26.92	13.45
Pavement Marking Machine (ZONE 2: STATEWIDE (EXCLUDING GENESEE, MACOMB, MONROE, OAKLAND, WASHTENAW AND WAYNE) Group 2.....	\$ 24.23	13.45

WORK CLASSIFICATIONS:

PAVEMENT MARKER GROUP 1: Drives or operates a truck mounted striper, grinder, blaster, groover, or thermoplastic melter for the placement or removal of temporary or permanent pavement markings or markers.

PAVEMENT MARKER GROUP 2: Performs all functions involved for the placement or removal of temporary or permanent pavement markings or markers not covered by the classification of Pavement Marker Group 1 or Line Protector.

LINE PROTECTOR: Performs all operations for the protection or removal of temporary or permanent pavement markings or markers in a moving convoy operation not performed by the classification of Pavement Marker Group 1. A moving convoy operation is comprised of only Pavement Markers Group 1 and Line Protectors.

-----  
WELDERS - Receive rate prescribed for craft performing operation to which welding is incidental.

\*\*\*\*\*

\*\* Workers in this classification may be entitled to a higher minimum wage under Executive Order 14026 (\$17.75) or 13658 (\$13.30). Please see the Note at the top of the wage determination for more information. Please also note that the minimum wage requirements of Executive Order 14026 are not currently being enforced as to any contract or subcontract to which the states of Texas, Louisiana, or Mississippi, including their agencies, are a party.

Note: Executive Order (EO) 13706, Establishing Paid Sick Leave for Federal Contractors applies to all contracts subject to the Davis-Bacon Act for which the contract is awarded (and any solicitation was issued) on or after January 1, 2017. If this contract is covered by the EO, the contractor must provide employees with 1 hour of paid sick leave for every 30 hours they work, up to 56 hours of paid sick leave each year. Employees must be permitted to use paid sick leave for their own illness, injury or other health-related needs, including preventive care; to assist a family member (or person who is like family to the employee) who is ill, injured, or has other health-related needs, including preventive care; or for reasons resulting from, or to assist a family member (or person who is like family to the employee) who is a victim of, domestic violence, sexual assault, or stalking. Additional information on contractor requirements and worker protections under the EO is available at <https://www.dol.gov/agencies/whd/government-contracts>.

Unlisted classifications needed for work not included within the scope of the classifications listed may be added after award only as provided in the labor standards contract clauses (29CFR 5.5 (a) (1) (iii)).

-----

The body of each wage determination lists the classifications and wage rates that have been found to be prevailing for the type(s) of construction and geographic area covered by the wage determination. The classifications are listed in alphabetical order under rate identifiers indicating whether the particular rate is a union rate (current union negotiated rate), a survey rate, a weighted union average rate, a state adopted rate, or a supplemental classification rate.

#### Union Rate Identifiers

A four-letter identifier beginning with characters other than ""SU"", ""UAVG"", ?SA?, or ?SC? denotes that a union rate was prevailing for that classification in the survey. Example: PLUM0198-005 07/01/2024. PLUM is an identifier of the union whose collectively bargained rate prevailed in the survey for this classification, which in this example would be Plumbers. 0198 indicates the local union number or district council number where applicable, i.e., Plumbers Local 0198. The next number, 005 in the example, is an internal number used in processing the wage determination. The date, 07/01/2024 in the example, is the effective date of the most current negotiated rate.

Union prevailing wage rates are updated to reflect all changes over time that are reported to WHD in the rates in the collective bargaining agreement (CBA) governing the classification.

#### Union Average Rate Identifiers

The UAVG identifier indicates that no single rate prevailed for those classifications, but that 100% of the data reported for the classifications reflected union rates. EXAMPLE: UAVG-OH-0010 01/01/2024. UAVG indicates that the rate is a weighted union average rate. OH indicates the State of Ohio.

The next number, 0010 in the example, is an internal number used in producing the wage determination. The date, 01/01/2024 in the example, indicates the date the wage determination was updated to reflect the most current union average rate.

A UAVG rate will be updated once a year, usually in January, to reflect a weighted average of the current rates in the collective bargaining agreements on which the rate is based.

#### Survey Rate Identifiers

The ""SU"" identifier indicates that either a single non-union rate prevailed (as defined in 29 CFR 1.2) for this classification in the survey or that the rate was derived by computing a weighted average rate based on all the rates reported in the survey for that classification. As a weighted average rate includes all rates reported in the survey, it may include both union and non-union rates. Example: SUFL2022-007 6/27/2024. SU indicates the rate is a single non-union prevailing rate or a weighted average of survey data for that classification. FL indicates the State of Florida. 2022 is the year of the survey on which these classifications and rates are based. The next number, 007 in the example, is an internal number used in producing the wage determination. The date, 6/27/2024 in the example, indicates the survey completion date for the classifications and rates under that identifier.

?SU? wage rates typically remain in effect until a new survey is conducted. However, the Wage and Hour Division (WHD) has the discretion to update such rates under 29 CFR 1.6(c)(1).

State Adopted Rate Identifiers

The ""SA"" identifier indicates that the classifications and prevailing wage rates set by a state (or local) government were adopted under 29 C.F.R 1.3(g)-(h). Example: SAME2023-007 01/03/2024. SA reflects that the rates are state adopted. ME refers to the State of Maine. 2023 is the year during which the state completed the survey on which the listed classifications and rates are based. The next number, 007 in the example, is an internal number used in producing the wage determination. The date, 01/03/2024 in the example, reflects the date on which the classifications and rates under the ?SA? identifier took effect under state law in the state from which the rates were adopted.

WAGE DETERMINATION APPEALS PROCESS

1) Has there been an initial decision in the matter? This can be:

- a) a survey underlying a wage determination
- b) an existing published wage determination
- c) an initial WHD letter setting forth a position on a wage determination matter
- d) an initial conformance (additional classification and rate) determination

On survey related matters, initial contact, including requests for summaries of surveys, should be directed to the WHD Branch of Wage Surveys. Requests can be submitted via email to davisbaconinfo@dol.gov or by mail to:

Branch of Wage Surveys  
 Wage and Hour Division  
 U.S. Department of Labor  
 200 Constitution Avenue, N.W.  
 Washington, DC 20210

Regarding any other wage determination matter such as conformance decisions, requests for initial decisions should be directed to the WHD Branch of Construction Wage Determinations. Requests can be submitted via email to BCWD-Office@dol.gov or by mail to:

Branch of Construction Wage Determinations  
 Wage and Hour Division  
 U.S. Department of Labor  
 200 Constitution Avenue, N.W.  
 Washington, DC 20210

2) If an initial decision has been issued, then any interested party (those affected by the action) that disagrees with the decision can request review and reconsideration from the Wage and Hour Administrator (See 29 CFR Part 1.8 and 29 CFR Part 7). Requests for review and reconsideration can be submitted via email to dba.reconsideration@dol.gov or by mail to:

Wage and Hour Administrator  
 U.S. Department of Labor  
 200 Constitution Avenue, N.W.  
 Washington, DC 20210

The request should be accompanied by a full statement of the interested party's position and any information (wage payment data, project description, area practice material, etc.) that the requestor considers relevant to the issue.

3) If the decision of the Administrator is not favorable, an interested party may appeal directly to the Administrative Review Board (formerly the Wage Appeals Board). Write to:

Administrative Review Board  
 U.S. Department of Labor  
 200 Constitution Avenue, N.W.  
 Washington, DC 20210.

=====

END OF GENERAL DECISION"