

# Capital Area Transportation Authority



## AMENDMENT NO. 1 TO LOT LIGHT BASE REPLACEMENT

1. AMENDMENT NO: 1	2. SOLICITATION NO: RFQ 2019-503	3. SOLICITATION NAME: Lot Light Base Replacement	4. AMENDMENT DATE: May 2, 2019
-----------------------	-------------------------------------	---	-----------------------------------

5. ISSUED BY

Capital Area Transportation Authority  
Purchasing and Contracts Department  
4615 Tranter Street  
Lansing, MI 48910

**PLEASE NOTE: Contractor is required to sign this document and return it with the bid/proposal/quote.**

6. DESCRIPTION OF AMENDMENT:

The following documentation has been attached to this Amendment:

- a) Please note Exhibit A: Scope of Work has changed. A "REVISED" Scope of Work, Exhibit A is attached to include: Each contractor should make every effort to include Disadvantaged Business Enterprises in this project. CATA has a Disadvantaged Business Enterprise goal of 1.24%.
- b) All other terms and conditions remain unchanged.

NAME / TITLE OF OFFEROR (Type or Print)	COMPANY NAME
(Signature of person authorized to sign)	(Date Signed)

---

**EXHIBIT A**  
**“REVISED” SCOPE OF WORK**

---

1. Objectives

The specific objectives for this Project are as follows:

- a) Secure a contract for lot light base replacements at Capital Area Transportation Authority (“CATA”) Tranter Street facility.

2. General Provisions

- a) The contractor shall furnish all labor, tools and materials necessary for the lot light base replacement as listed in this Scope of Work.
- b) The Contractor shall provide the Project Manager with a work schedule.
- c) The Contractor assumes full responsibility for protection and safekeeping of materials and equipment on-site.
- d) All work must conform to all state and local construction regulations. The contractor will be responsible for obtaining and paying for all required permits. The contractor will be responsible for coordinating and scheduling all work with CATA Staff, Miss Dig and local municipalities and jurisdictions.
- e) The Contractor will notify the CATA Project Manager of any findings during the project and submit a cost proposal for any additional work required. No additional work shall commence until approved by the Project Manager.
- f) The Contractor will be responsible to clean up at the end of each work day.

3. Service Period

CATA intends to award a firm, fixed price contract.

4. Scope of Work

The Capital Area Transportation Authority (“CATA”) is requesting quotations from vendors for the rehabilitation of three (3) lot light bases located in the employee parking lot at 4615 Tranter St., Lansing, MI 48910. (Tranter Street Facility)

- a) Contractor to disconnect power and remove the poles. Poles may be stored at the north end of parking lot which CATA will cone off. Contractor is responsible for coning off the work area around each light pole base.
- b) Contractor to cut surrounding asphalt from the three (3) lot light bases. Contract is responsible for removing and disposing of existing materials, offsite.
- c) Site prep to spec. (*See Attachment A*)
- d) Contractor to provide and install three (3) lot light base’s size and structure equivalent to existing base’s being removed, including all necessary conduits. Drawing /Diagram is provided. (*See Attachment A*)
- e) The three (3) new concrete base locations are to be painted with safety yellow exterior epoxy.
- f) Contractor to re-install three (3) lot light poles and connect. Contractor must test operation on all three (3) lot light poles.
- g) Contractor to re-install new asphalt to match existing asphalt and must be sloped in accordance with Attachment A from the new bases. Soil should be prepped in accordance with the attached spec.

- h) Contractor to pull all necessary permits.
- i) See site map for pole base locations. (*See Attachment B*)
- j) See 'Pole Base Detail' for specs. (*See Attachment A*)
- k) All soils removed should be replaced with 21 AA gravel and compacted to 95% minimum.

Payment shall be made as follows; 75% upon completion of the three (3) lot light bases; remaining 25% will be paid upon receipt of certified payroll records (for prevailing wage), providing the records meet CATA's requirements.

CATA requires the work to be completed on or before, Friday, June 21, 2019 @ 5:00 P.M. Eastern Time.

Each contractor should make every effort to include Disadvantaged Business Enterprises in this project. CATA has a Disadvantaged Business Enterprise goal of 1.24%.

**END OF THIS SECTION**

### ATTACHMENT A

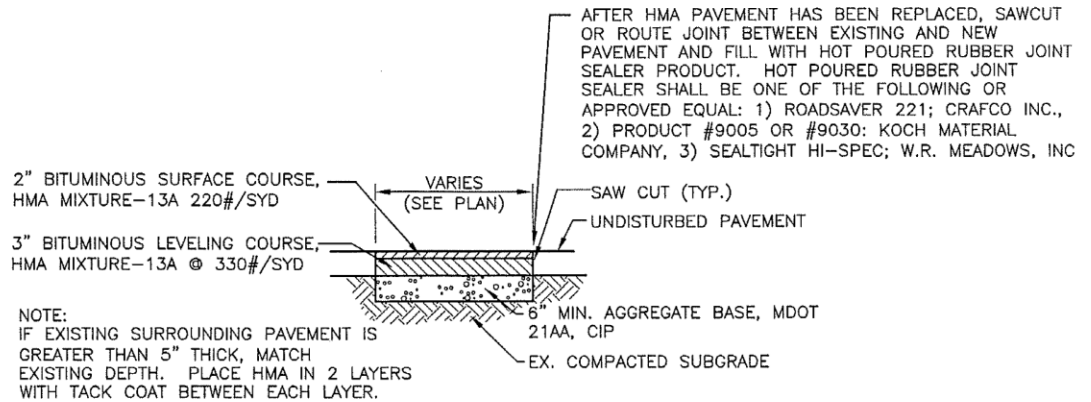

- ① NEW SURFACE SHALL BE SLOPED AT THE SAME SLOPE AS THE EXISTING SURFACE.
- ② EXISTING PAVEMENT SHALL BE SAW CUT. CUT EDGES STRAIGHT & SMOOTH.
- ③ BASE COURSE SHALL BE LAID AT 4" (MIN.) LIFTS AND SHALL BE COMPACTED TO A MINIMUM OF 95%.
- ④ UNIFORMLY APPLY TACK COAT, SS-1H, RATE: 0.10 TO 0.15 GALLON PER SYD OVER ENTIRE SURFACE OF EACH BITUMINOUS COURSE, EXCEPT THE LAST ONE, AND TO THE SIDES OF THE EXISTING PAVEMENT THAT WERE SAW CUT.
- ⑤ TRENCH SPOIL SHALL BE REMOVED FROM THE WORK SITE.

### ASPHALT PAVEMENT REPAIR DETAIL

SCALE: N.T.S.

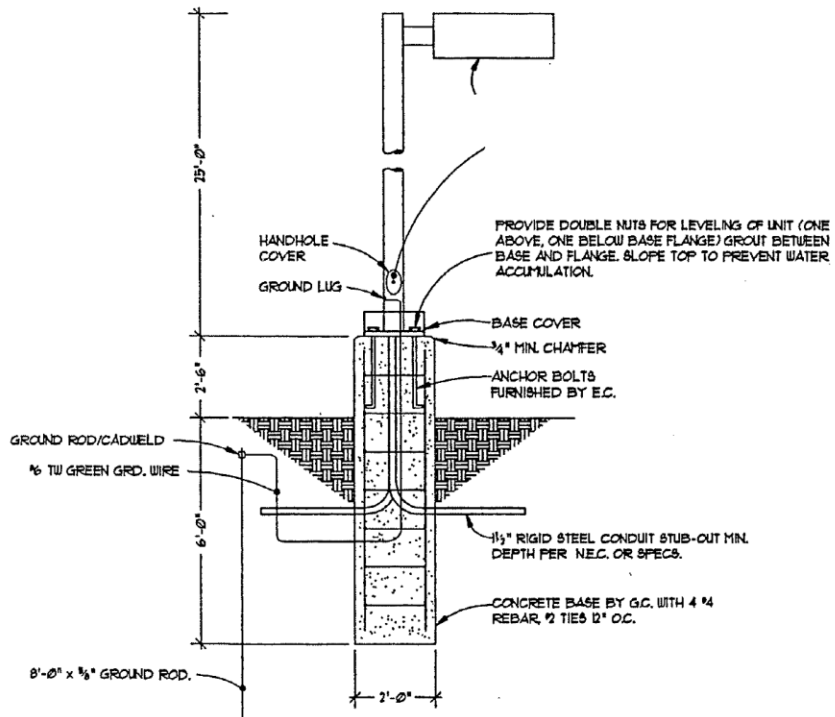

### POLE BASE DETAIL

SCALE: N.T.S.

### ATTACHMENT B

### SITE MAP

